

<h3>Library 2.0 Bookshelf System Logic</h3>  <p><b>Tools Required</b></p> <ul style="list-style-type: none"> <li>• Rubber Mallet</li> <li>• #3 Phillips Screw Driver</li> <li>• Powered Driver with 1/4" Socket Bit Extension</li> <li>• #2 Driver Bit</li> <li>• 1/2" Wrench (2)</li> <li>• Protective Gloves</li> </ul>	<h3>Starter Components</h3>  <p><b>Hardware List</b></p> <ul style="list-style-type: none"> <li>• One Sided Pins</li> <li>• Cams</li> <li>• 2x2 Brackets</li> <li>• #10 X .625" Pan Head Wood Screws</li> <li>• #10 X 1.25" Pan Head Wood Screws</li> <li>• #10 X 1.5" Flat Head Wood Screws</li> <li>• Shelf Hardware (<i>varies</i>)</li> </ul>
<h3>Adder Components</h3>  <p><b>Hardware List</b></p> <ul style="list-style-type: none"> <li>• Two Sided Pins</li> <li>• Cams</li> <li>• 2x2 Brackets</li> <li>• #8 X .750" Pan Head Wood Screws</li> <li>• #10 X .625" Pan Head Wood Screws</li> <li>• #10 X 1.5" Flat Head Wood Screws</li> <li>• 5/16" X 3" Bolts</li> <li>• Flat Washers</li> <li>• 5/16" Flanged Nuts</li> <li>• Shelf Hardware (<i>varies</i>)</li> </ul>	<h3>Finishing End Panel Components</h3>  <p><b>Hardware List</b></p> <ul style="list-style-type: none"> <li>• One Sided Pins</li> <li>• #10 X .625" Pan Head Wood Screws</li> <li>• #10 X 1.25" Pan Head Wood Screws</li> <li>• Shelf Hardware (<i>varies</i>)</li> </ul>

1. Locate LH or RH End (depending on which direction you will be building the run), One Sided Pins, and Cams. RH end panels can be quickly identified by three closely spaced markings near the bottom of the panel. Lay end panel flat on ground with holes facing up. Press 2 cams into the largest holes at the top of the end panel while making sure that the **straight arrows on cam are pointed towards the closest edge of the panel**. Press single sided pins into each of the larger holes along rear of the end panel.

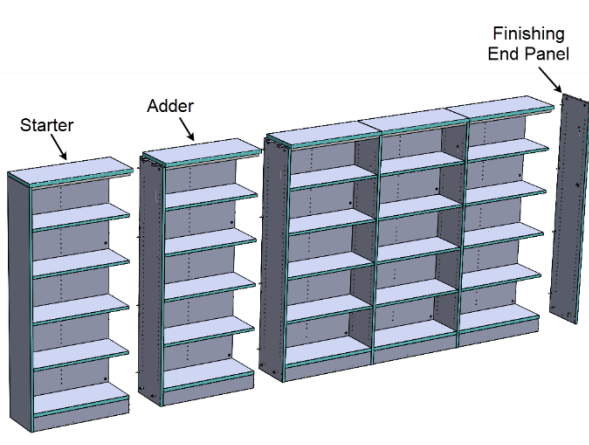

2. Locate a base assembly and (3) #10 X 1.25" pan head wood screws. Place base assembly onto end panel while aligning the 2 wood dowels protruding from the toe kick. Fasten base assembly to end panel with (3) #10 X 1.25" pan head wood screws through the smaller holes in the base rail. Tighten to a torque of 35 in-lbs. **Do not overtighten.**

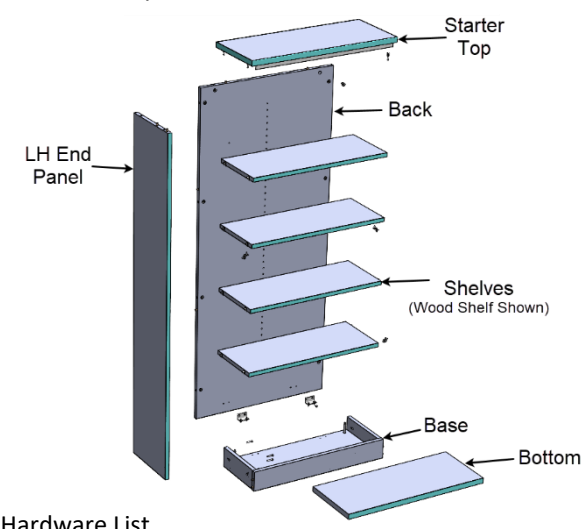
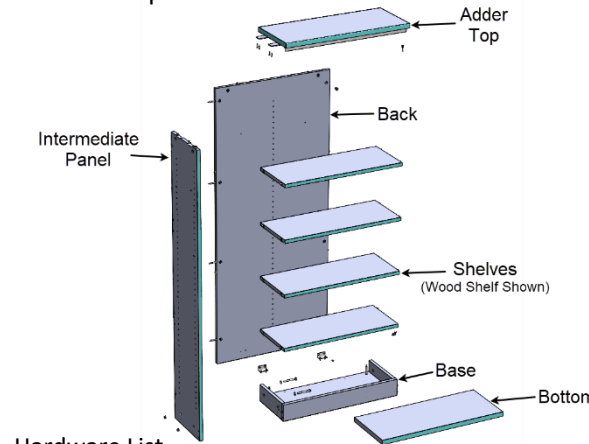
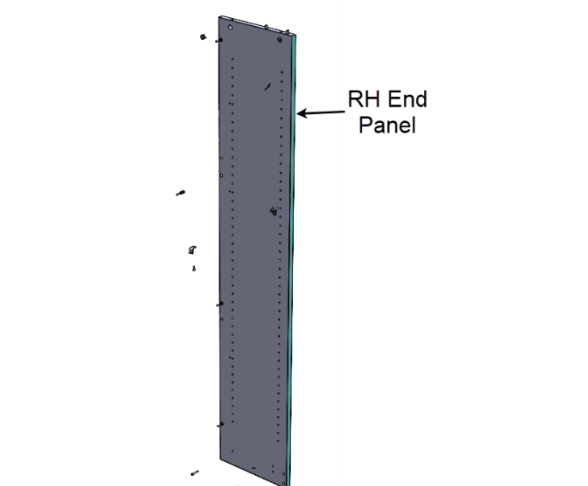
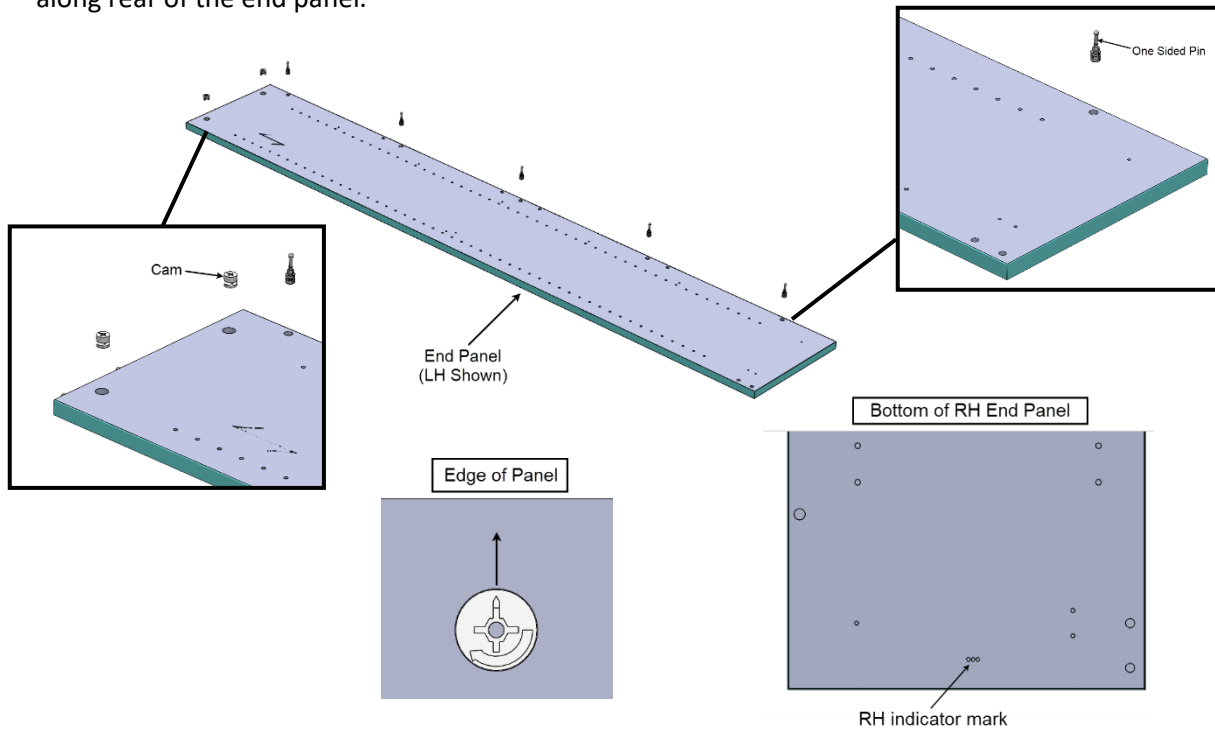
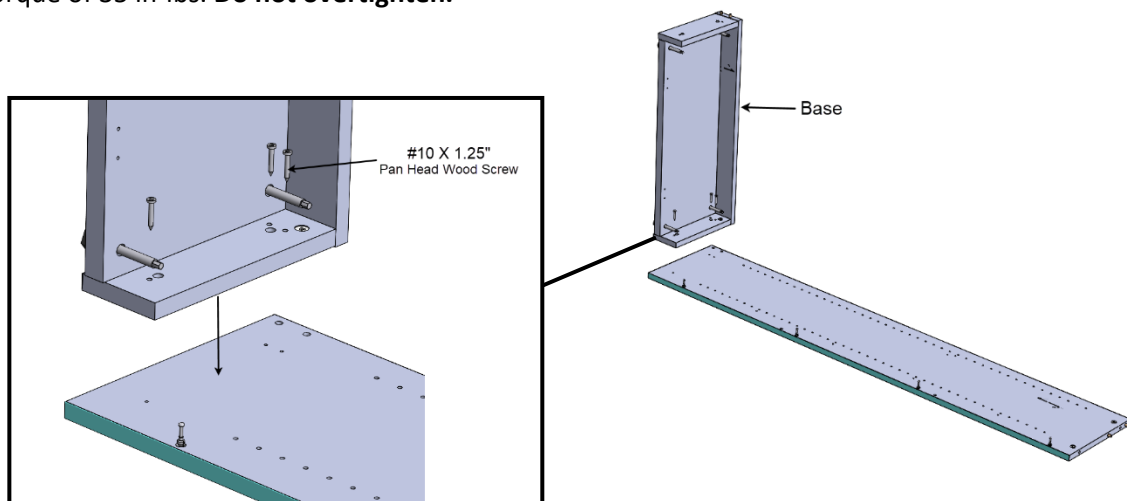

3. Locate Back, 2x2 brackets, #10 X .625" pan head wood screws and cams. Push cams into large holes along the perimeter of the back, making sure the **straight arrows point directly towards the closest edge of the panel**. Attach 2x2 brackets to back with (4) #10 X .625" pan head screws using the predrilled holes provided at the bottom of the panel. Note: Unfinished edges of parts are very sharp – we recommend wearing protective gloves when handling.

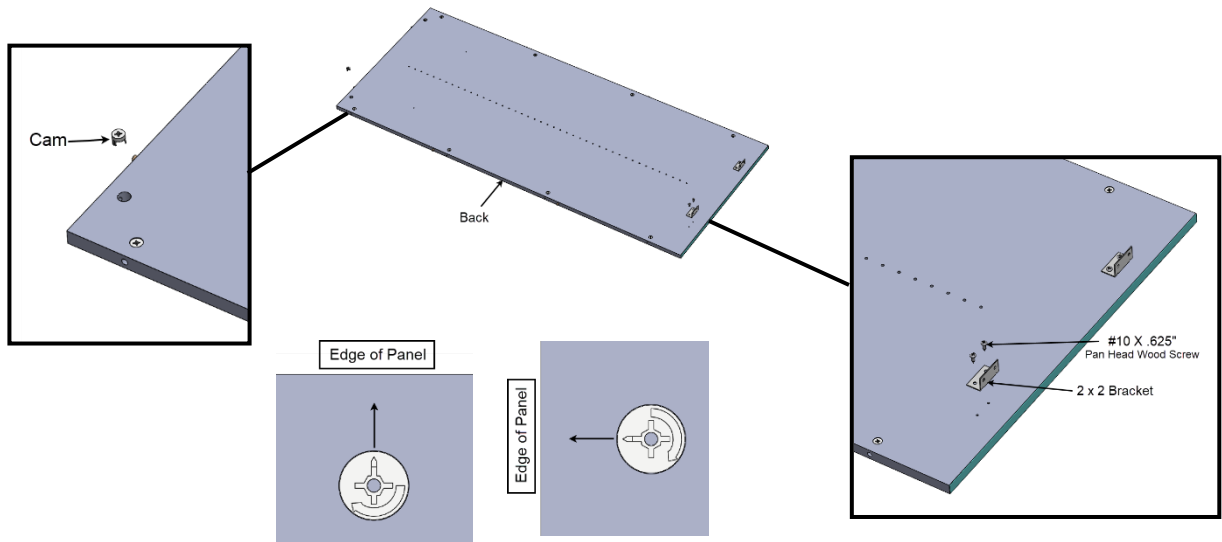

4. Carefully place back onto end while aligning the pins in the end with the cams in back. This may take two people for larger sizes. Using a #3 Phillips Screwdriver, turn the cams along the left side of the Back clockwise until you reach 12-1 o'clock and gaps are closed.

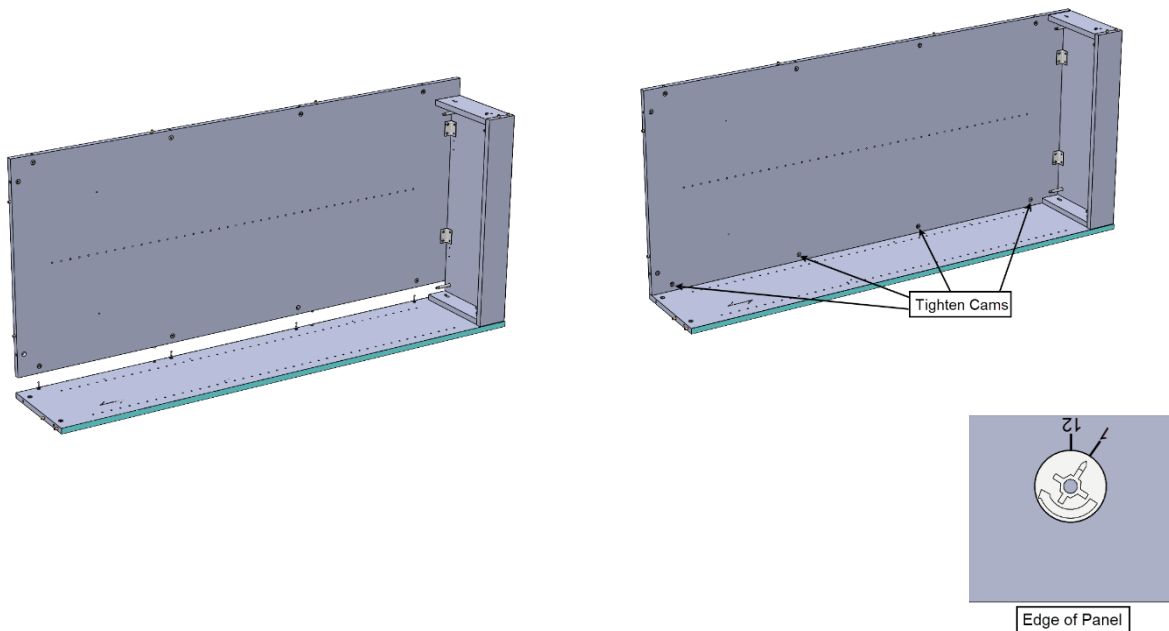

5. Use (4) #10 X .625 pan head wood screws to secure the brackets to the Base Assembly using the provided predrilled holes.

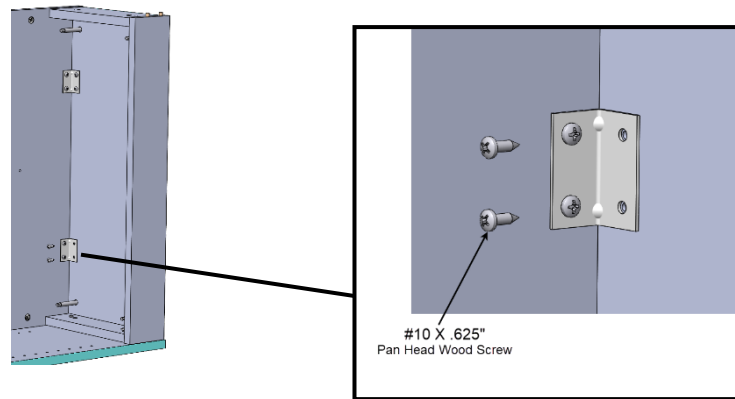

6. Once all screws are installed and back cams are tightened. Carefully flip the product upright and move into position. If only assembling one bookshelf, skip to step 13.

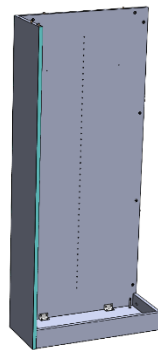

7. Locate double sided pins. Feed a double-sided pin into each of the cams along the side of the back. Turn the cams to 10 o'clock. This is just enough to lock the pins in while allowing them to connect to the cams in the next back.

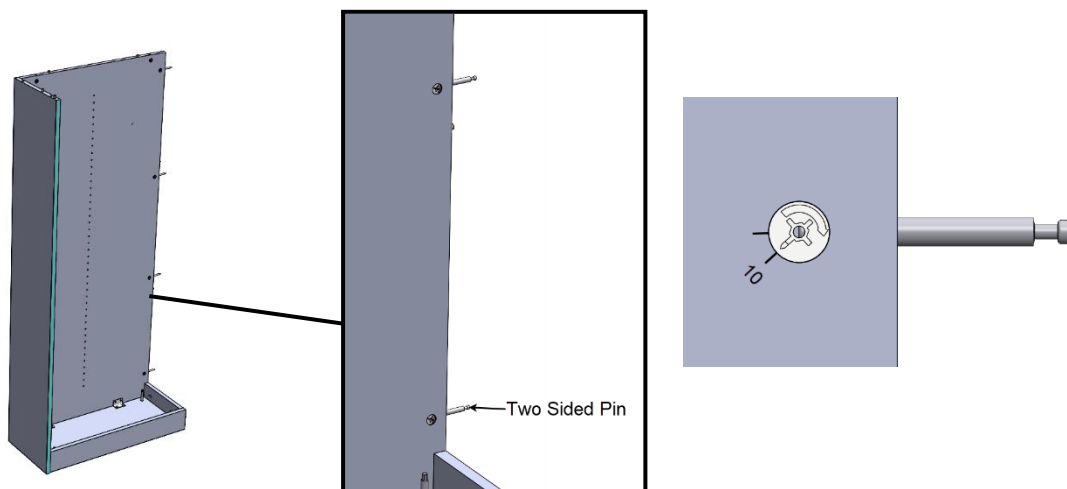

8. Locate an Intermediate Panel and (2) Cams. Intermediate Panels have through holes and notches at the top. Press (2) cams into largest holes at the top of the intermediate panel while pointing straight arrows on cam directly towards the closest edge. Press intermediate panel to starter while aligning the holes with the pins and wood dowels in the back and toe kick.

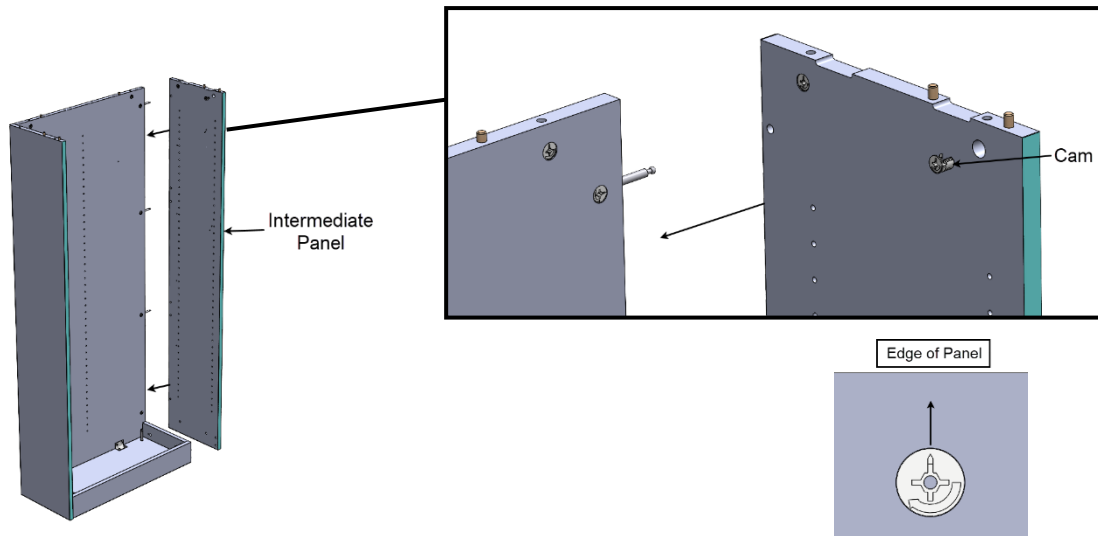

9. Locate next Base, (2) 5/16" X 3" Bolts, (2) Flat Washers, and (2) Flanged Nuts. Press Base to Intermediate Panel while aligning wood dowels in toe kick. It may be necessary to lightly tap the base assembly with a rubber mallet. Feed the (2) 5/16" X 3" bolts with flat washers through the slotted holes in bases and through the holes in the intermediate panels. Thread a flanged nut onto each bolt. Tighten bolts/nuts with (2) 1/2" wrenches until gaps between base assembly rails and the intermediate panel are closed

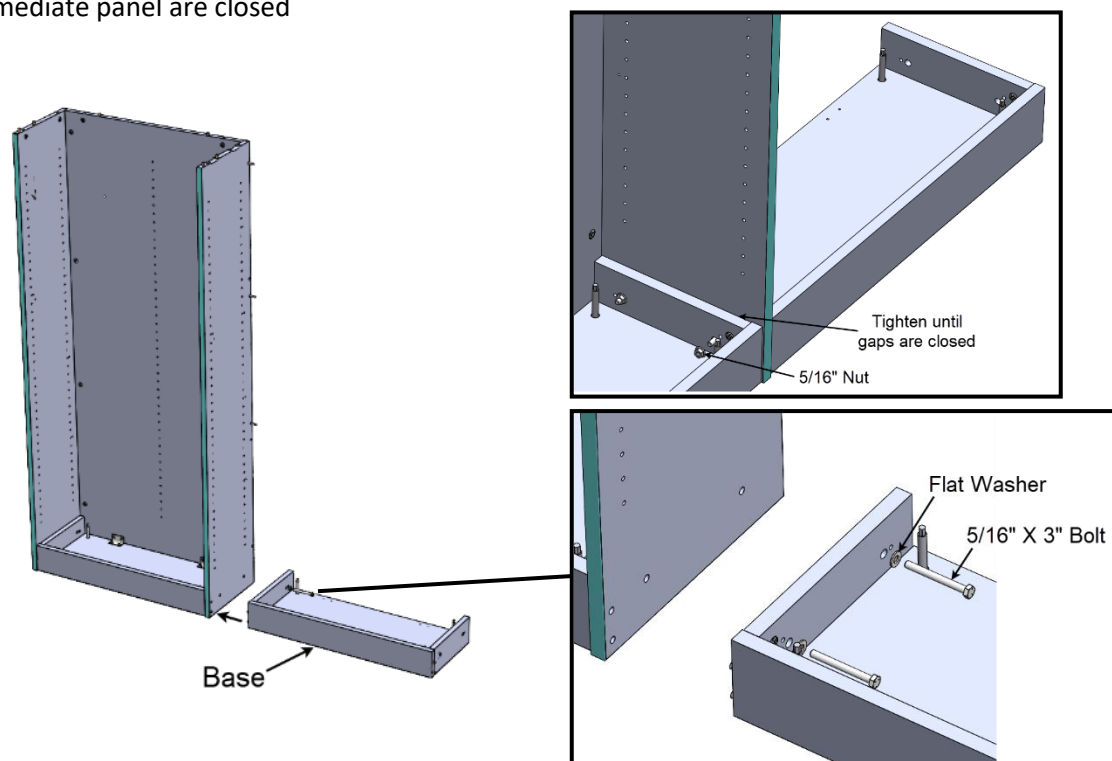

**10.** Locate the next Back, Cams, 2x2 Brackets, and #10 X .625" pan head wood screws. Press cams into each of the large holes with arrow pointed directly towards the edge. Attach the (2) 2x2 brackets to the Back with (4) #10 X .625" pan head screws using the predrilled holes as you did in step 3.

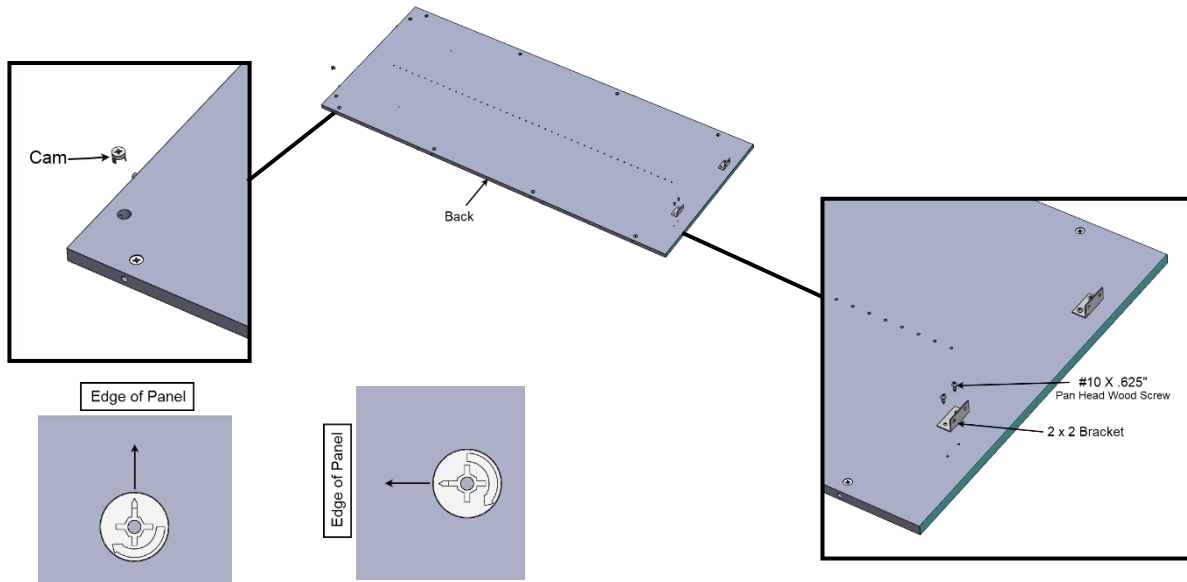

**11.** Place Back into position with the brackets resting on the Base Assembly. Slide the Back to the Intermediate Panel while aligning the wood dowels and pins. You may need to use a rubber mallet to tap the Back and flush it up to the Intermediate Panel. Tighten each of the cams to 12-1 o'clock and gaps are closed. Fasten brackets to Base Assembly with (4) #10 X .625" pan head screws.

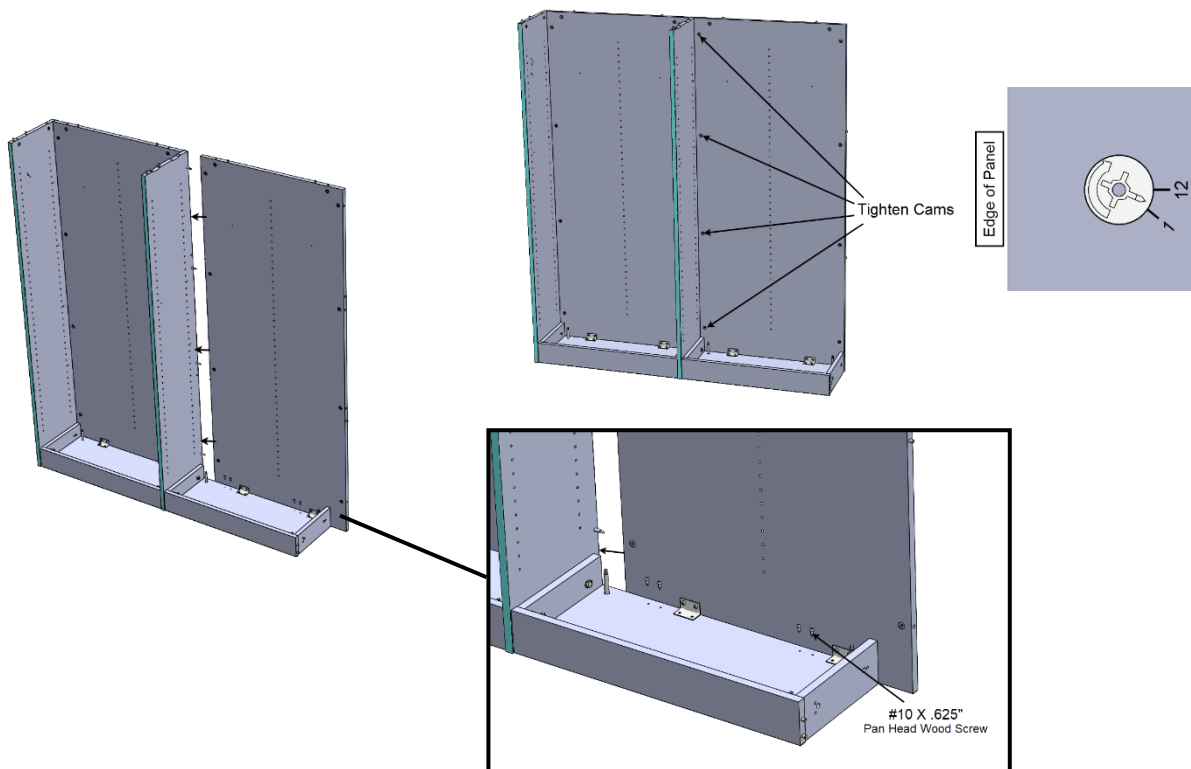

**12.** Repeat steps 7-11 for remaining Adder Bookcases. For wall to wall fit ups, it may be necessary for run be built angled away from the wall and then moved into final position once end panels/fillers are installed. Due to pins and dowels, you will need roughly 1" more space than the final run dimension to install the finishing end panel.

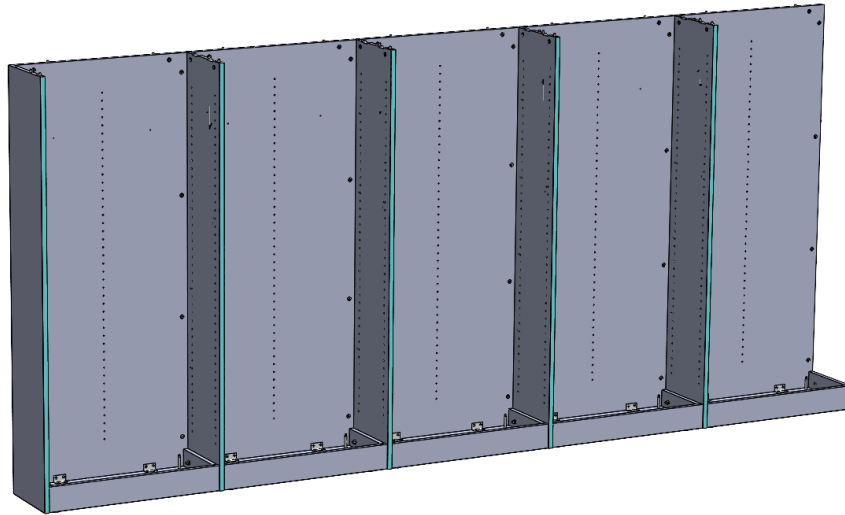

**13.** Locate Finishing End Panel (RH or LH), Cams, and One Sided Pins. Press one sided pins into each of the larger holes along the perimeter of the End. While aligning the pins and wood dowels, tap the End until flush with Back and Base Assembly.

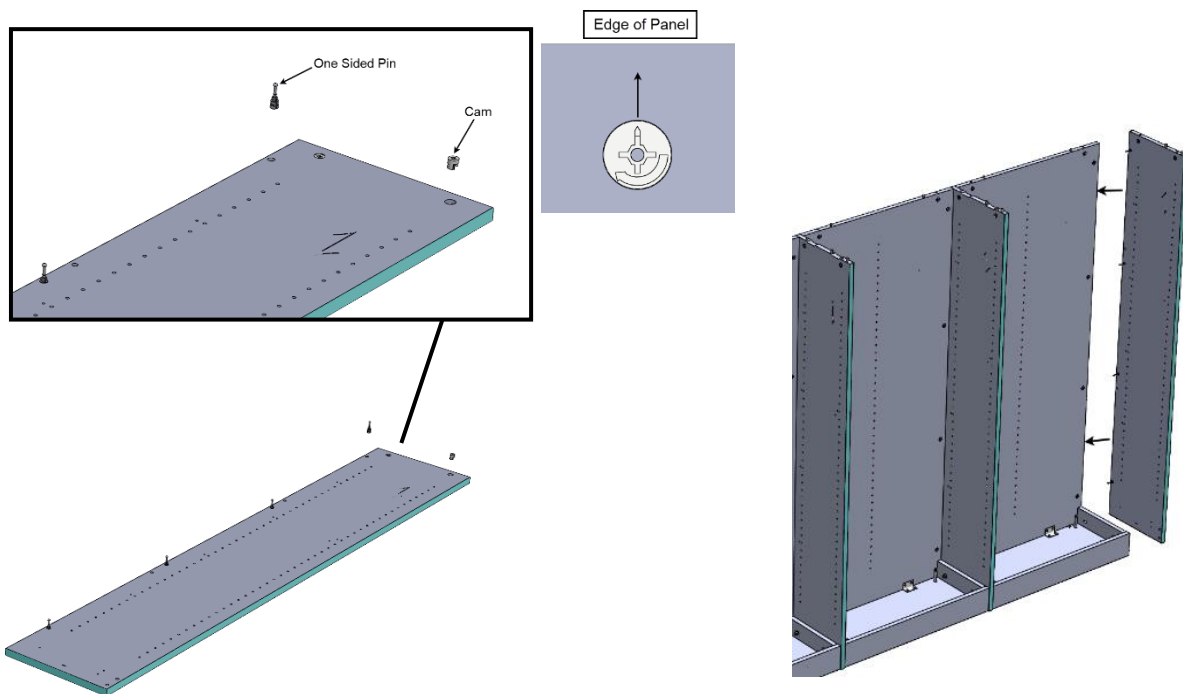

**14.** Locate (3) #10 X 1.25" pan head wood screws. Drive (3) #10 X 1.25" wood screws through the smaller holes in the Base Assembly into the End Panel. Tighten to a torque of 35 in-lbs. Do not overtighten. Tighten each of the cams in the Back to 12-1 o'clock. If only building one bookshelf, skip to step 16.

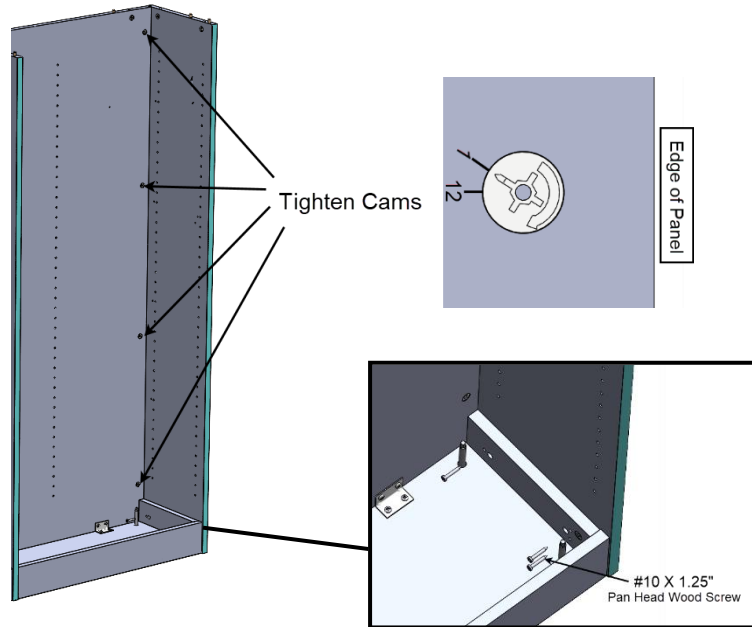

**15.** Locate the Adder Tops and One Sided Pins. Adder Tops are narrower than the Starter Top and will have mending plates attached to one side. Insert one sided pins into the larger holes along the back and edge of top. Starting with the right-most bookshelf, place an Adder Top onto the bookshelf while aligning the wood dowels and pins. Tap down with a rubber mallet. Tighten the cams in the back and end panel to 12 – 1 o'clock until gaps are closed. Repeat this step for remaining Adder Bookcases.

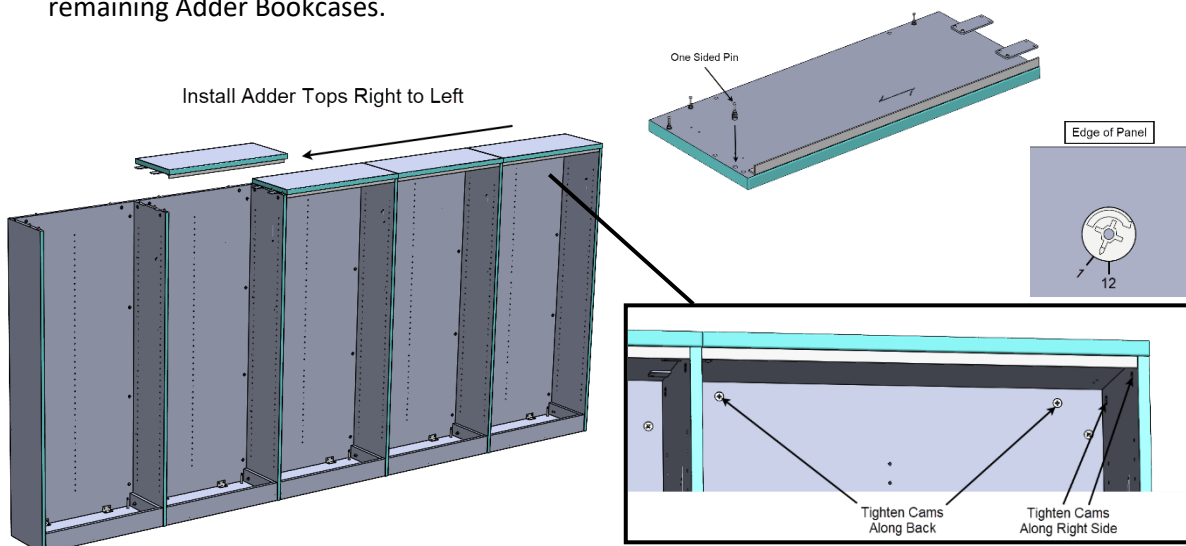



- 16.** Locate Starter Top and One Sided Pins. Insert one sided pins into the larger holes along the back and both sides of the top. The starter top will always be assembled to the left-most bookshelf. Place the top onto the bookcase while aligning the wood dowels and pins. Tap down with rubber mallet. Tighten cams in the Back and the end/intermediate panels to 12-1 o'clock. If only building one bookshelf, skip to step 18.

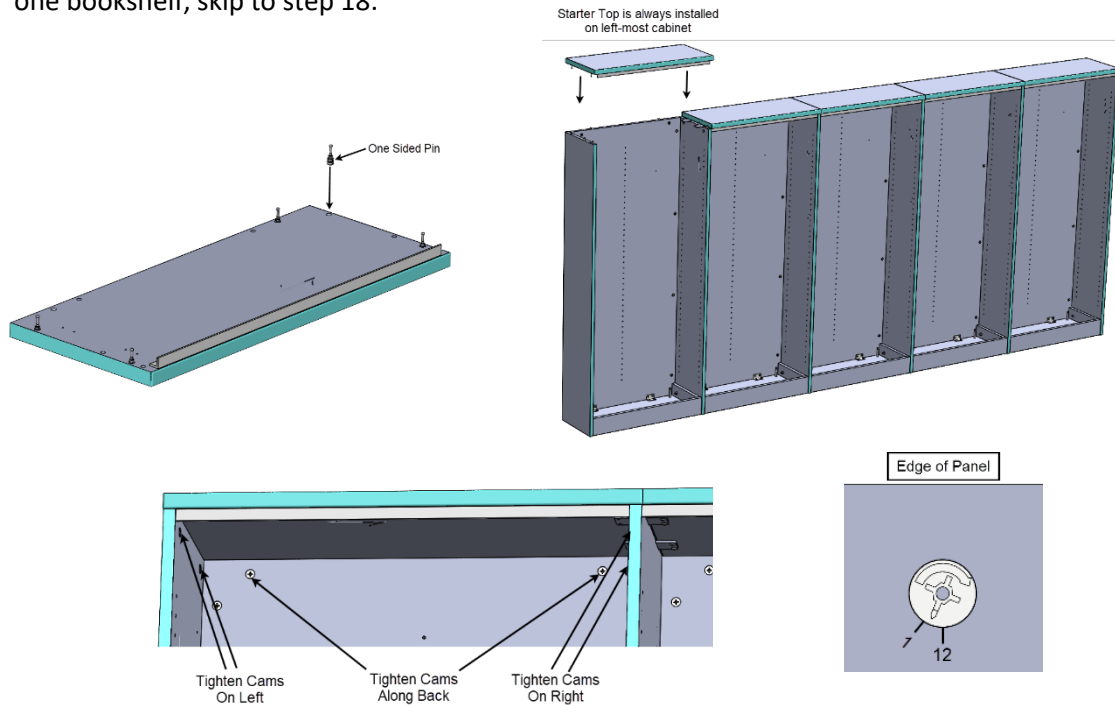

- 17.** Locate #8 X .750" pan head wood screws. Fasten mending plates on each adder top to adjacent top with (4) #8 X .750" pan head wood screws. This ensures that Adder tops are adequately supported.

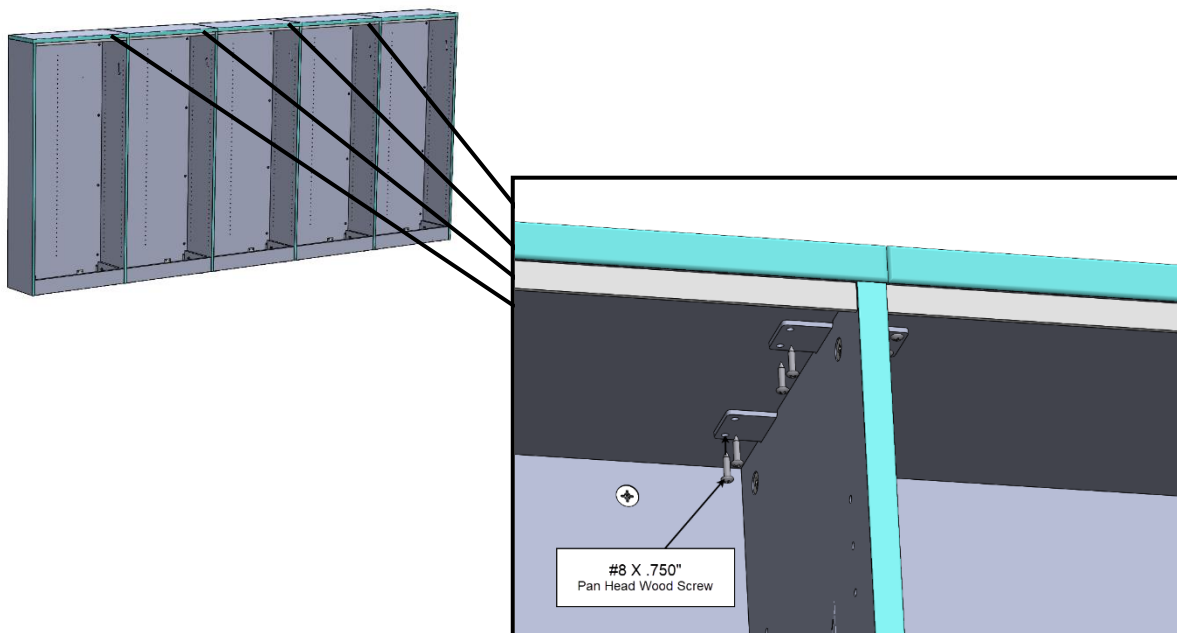

**18.** Ensure Bookshelves are level by adjusting levelers in base with  $\frac{1}{4}$ " socket. Tip: Bit extensions for drivers are  $\frac{1}{4}$ " sockets. We suggest leveling the first and last bookcases to level the entire run of bookcases first. Then go back and ensure all levelers are touching the ground. When finished leveling, locate the Bottoms and slide them onto each Base Assembly with bumpers closest to front.

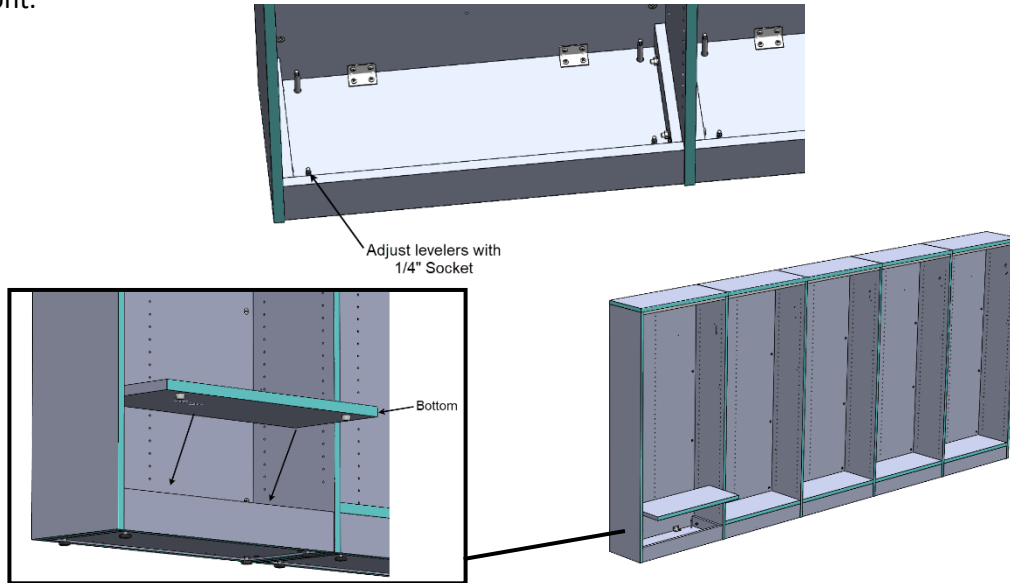

**19.** Bookshelves must be secured to building per local codes before use. Additionally, 24" wide single sided bookshelves acting as an end cap for double sided, must be fastened to double sided bookshelf if taller than 37". (2) #10 X 1.5" flat head wood screws are provided for each cabinet to attach single sided to the double sided. Two pre-drilled holes are provided in the backs for locating attachment screws behind top shelf in suggested location. They are also 16" apart to align with most building studs. Drill out holes in back with  $\frac{7}{32}$ " drill bit. Follow with a  $\frac{9}{64}$ " drill bit for predrilling the end panel in the double sided cabinet .500" deep. Attach single sided cabinet to double sided with the provided #10 X 1.5" flat head screws – do not overtighten. If attaching to building, use your own appropriate fasteners for the application.

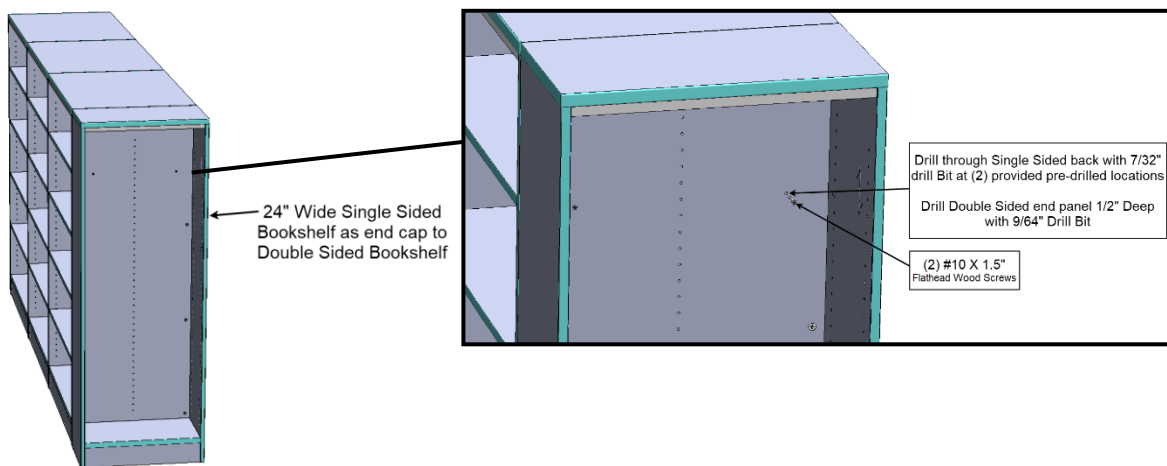

**20. Locate Shelves and Shelf Hardware.** Note there are different shelf types, each with their own hardware.

## Wood Shelves

Shelf Clips for wood shelves are as shown in the image below. Each wood shelf uses 5 shelf clips – 2 on each side and 1 in the back. Indicator marks behind the rear shelf clip holes in the end/intermediate panels give suggested shelf locations. Place pins the indicated shelf clips holes while making sure the pins in the ends and back are aligned with each other. Ensure that clips are pressed all the way into the holes by giving them a slight twist while inserting. Install shelf on shelf clips while fully seating pins into holes on underside of shelf.

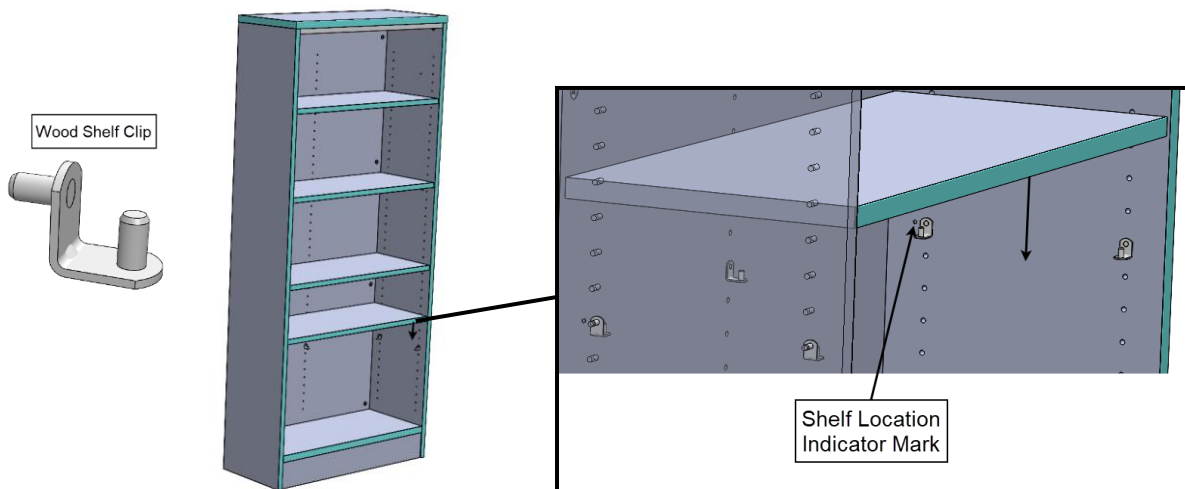

Cabinets 68" and taller require one fixed shelf on Freestanding and on 1<sup>st</sup> and last cabinet in a run to prevent end panel flexing. Angle brackets and #10 X .625" Pan Head Wood Screws are provided to fix 3<sup>rd</sup> shelf up. This shelf can be moved to different location, but predrilled holes are provided in suggested shelf location. Attach (2) angle brackets per fixed shelf with (2) #10 X .625" pan head wood screws in small, predrilled holes near the front of the shelf. Use (2) additional screws per shelf to attach bracket to end/intermediate panels.

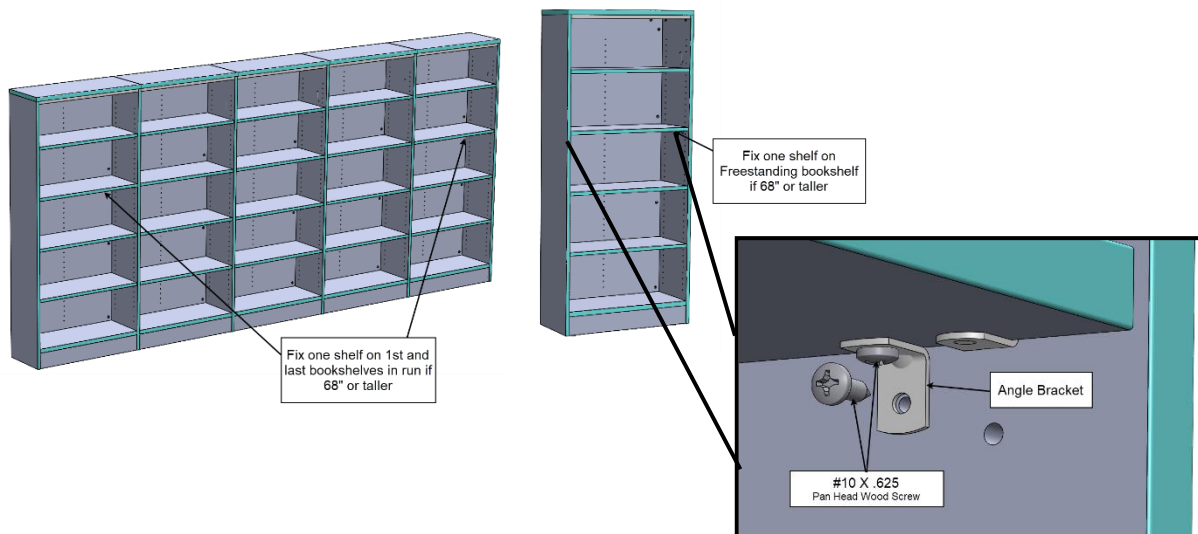

## Metal Shelves

Shelf Clips for metal shelves are as shown in the image below. Each metal shelf uses 4 shelf clips. Small indicator marks behind the shelf clip holes in the end/intermediate panels give suggested shelf locations. Place shelf clips in the indicated shelf clips holes while making sure the clips in the ends are aligned with each other.

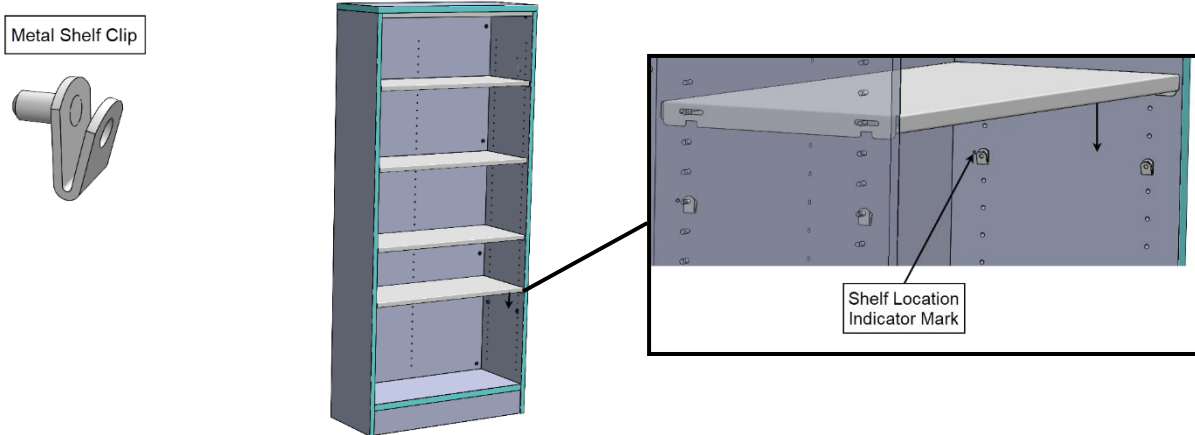

Cabinets 68H and taller require one fixed shelf on 1<sup>st</sup> and last cabinet in a run to prevent end panel flexing. #10 X .625" Pan Head Wood Screws are provided to fix 3<sup>rd</sup> shelf up. Predrilled holes are provided in the end/intermediate panels to drive #10 X .625" pan head wood screws through slots near front of metal shelf.

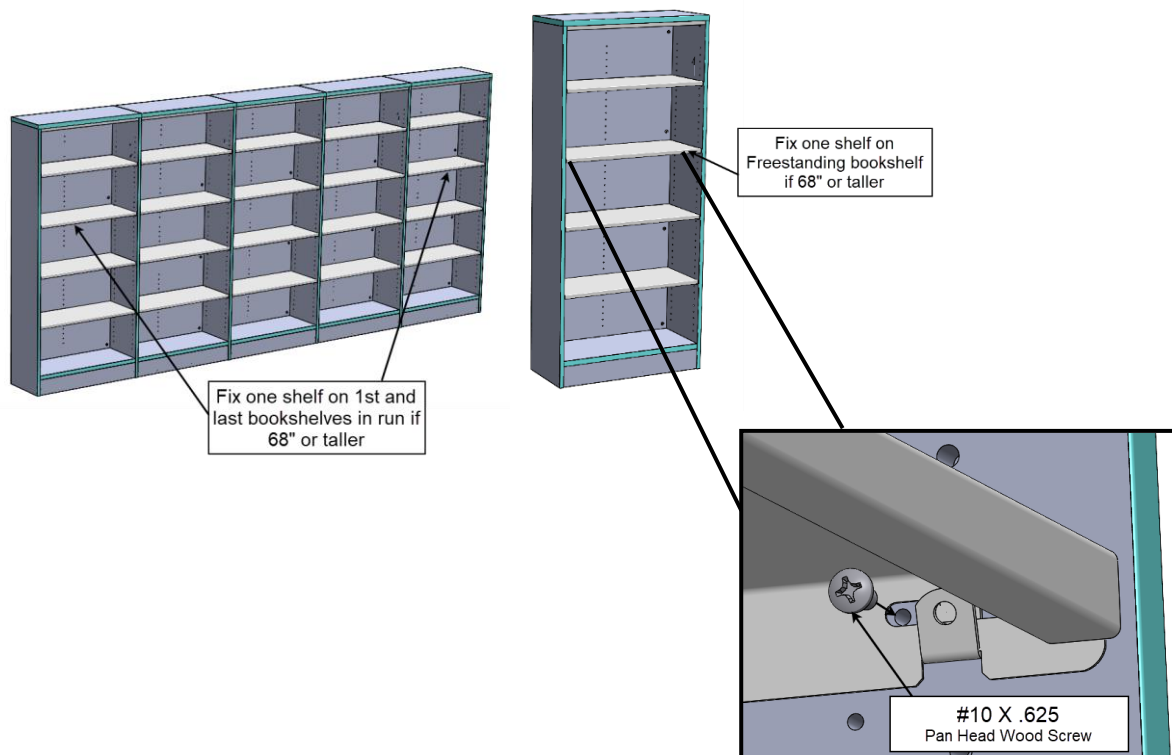

## Display Shelves

Straight shelf pins for display shelves are as shown in the image below. Each shelf uses 4 shelf pins. Front Shelf Pins must be spaced 8 holes down from rear shelf pins for pins to align with the slots in the shelves. To install shelf, align the keyhole slots in the rear of the shelf with the rear pins. Then, slide the shelf forward and rotate down as you align the front slots with the front pins.

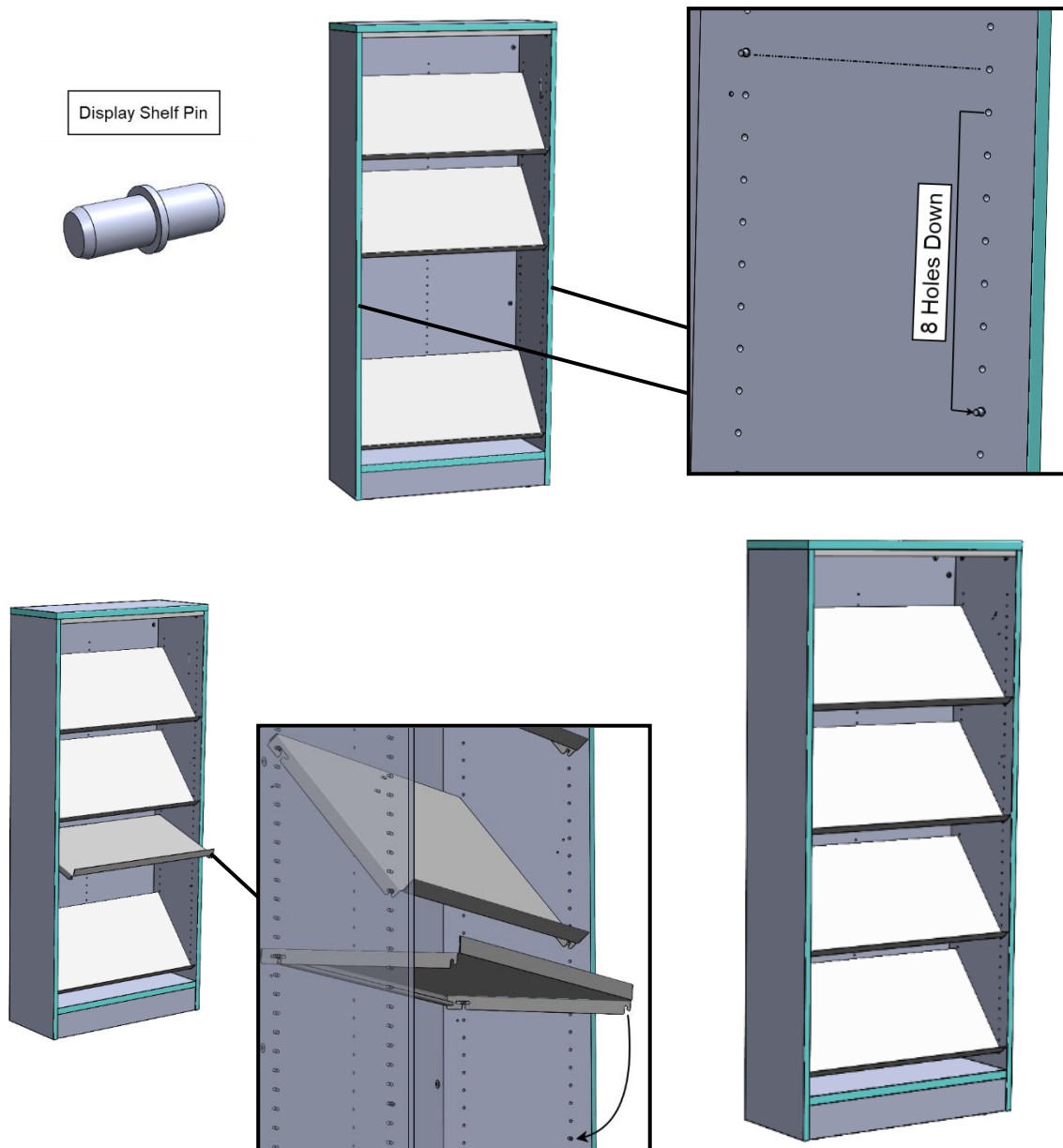

For questions please call us at (616) 396-1142

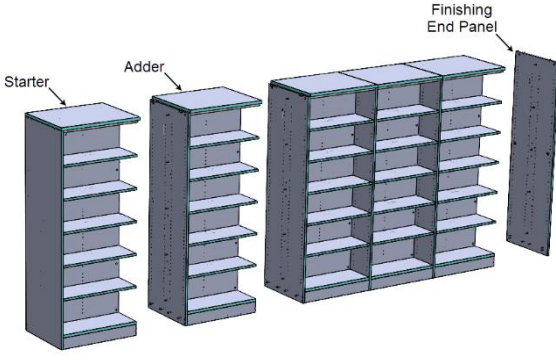
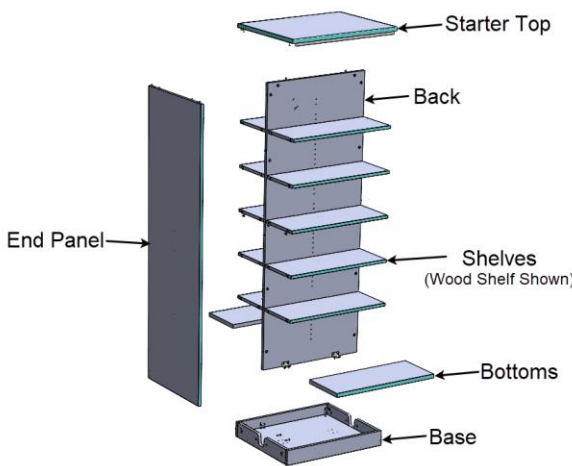
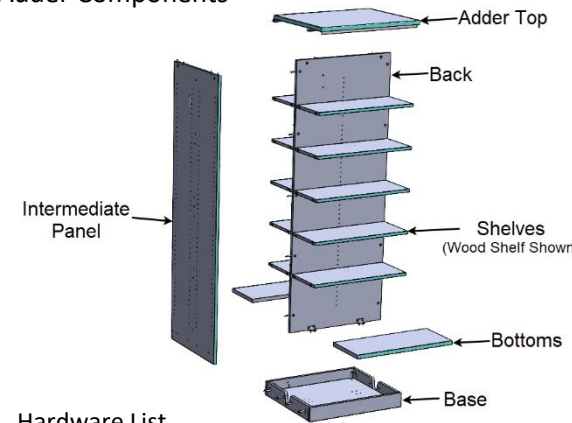
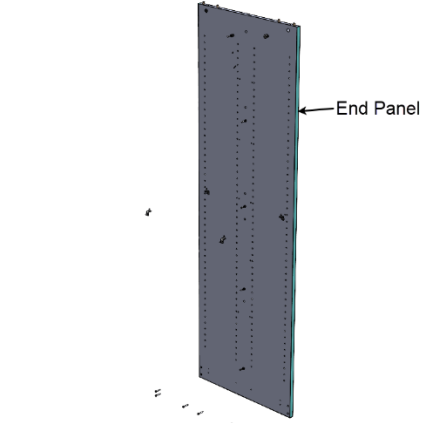
<h3>Library 2.0 Bookshelf System Logic</h3>  <p><b>Tools Required</b></p> <ul style="list-style-type: none"> <li>• Rubber Mallet</li> <li>• #3 Phillips Screw Driver</li> <li>• Powered Driver with 1/4" Socket Bit Extension</li> <li>• #2 Driver Bit</li> <li>• 1/2" Wrench (2)</li> <li>• Protective Gloves</li> </ul>	<h3>Starter Components</h3>  <p><b>Hardware List</b></p> <ul style="list-style-type: none"> <li>• One Sided Pins</li> <li>• Cams</li> <li>• 2x2 Brackets</li> <li>• #10 X .625" Pan Head Wood Screws</li> <li>• #10 X 1.25" Pan Head Wood Screws</li> <li>• #10 X 1.5" Flat Head Wood Screws</li> <li>• Shelf Hardware (<i>varies</i>)</li> </ul>
<h3>Adder Components</h3>  <p><b>Hardware List</b></p> <ul style="list-style-type: none"> <li>• Two Sided Pins</li> <li>• Cams</li> <li>• 2x2 Brackets</li> <li>• #8 X .750" Pan Head Wood Screws</li> <li>• #10 X .625" Pan Head Wood Screws</li> <li>• #10 X 1.5" Flat Head Wood Screws</li> <li>• 5/16" X 3" Bolts</li> <li>• Flat Washers</li> <li>• 5/16" Flanged Nuts</li> <li>• Shelf Hardware (<i>varies</i>)</li> </ul>	<h3>Finishing End Panel Components</h3>  <p><b>Hardware List</b></p> <ul style="list-style-type: none"> <li>• One Sided Pins</li> <li>• #10 X .625" Pan Head Wood Screws</li> <li>• #10 X 1.25" Pan Head Wood Screws</li> <li>• Shelf Hardware (<i>varies</i>)</li> </ul>

1. Locate an End (LH and RH are the same), One Sided Pins, and Cams. Lay end panel flat on ground with holes facing up. Press 2 cams into the largest holes at the top of the end panel while making sure that the **straight arrows on cam are pointed towards the closest edge of the panel**. Press single sided pins into each of the larger holes along the center of the panel.

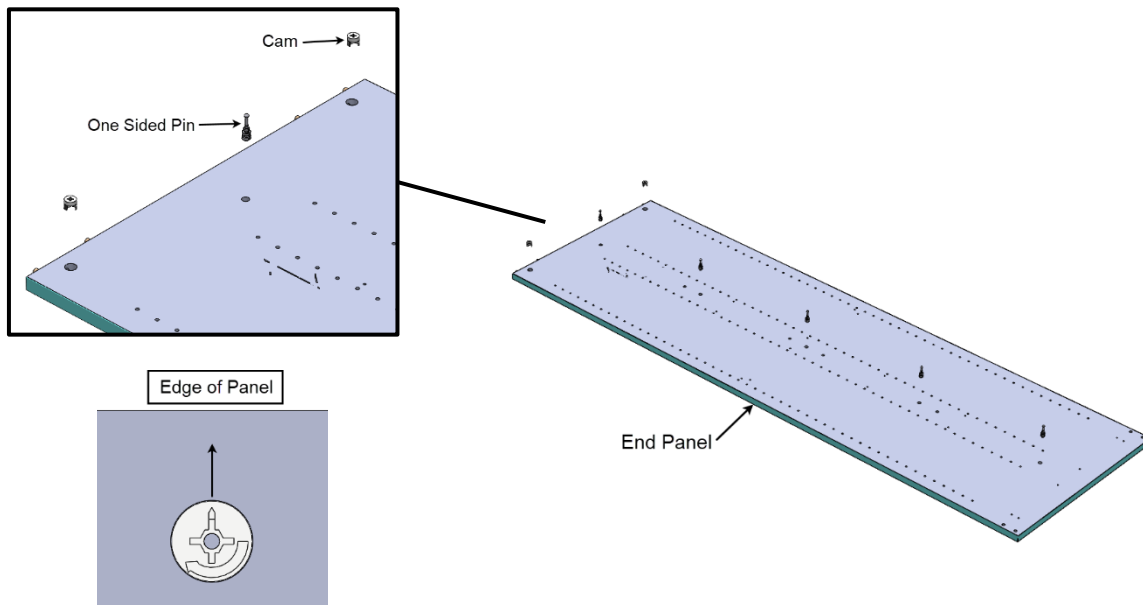

2. Locate a base assembly and (6) #10 X 1.25" pan head wood screws. Place base assembly onto end panel while aligning the 4 wood dowels protruding from the toe kicks. Fasten base assembly to end panel with (6) #10 X 1.25" pan head wood screws through the torque of 35 in-lbs. **Do not overtighten.**

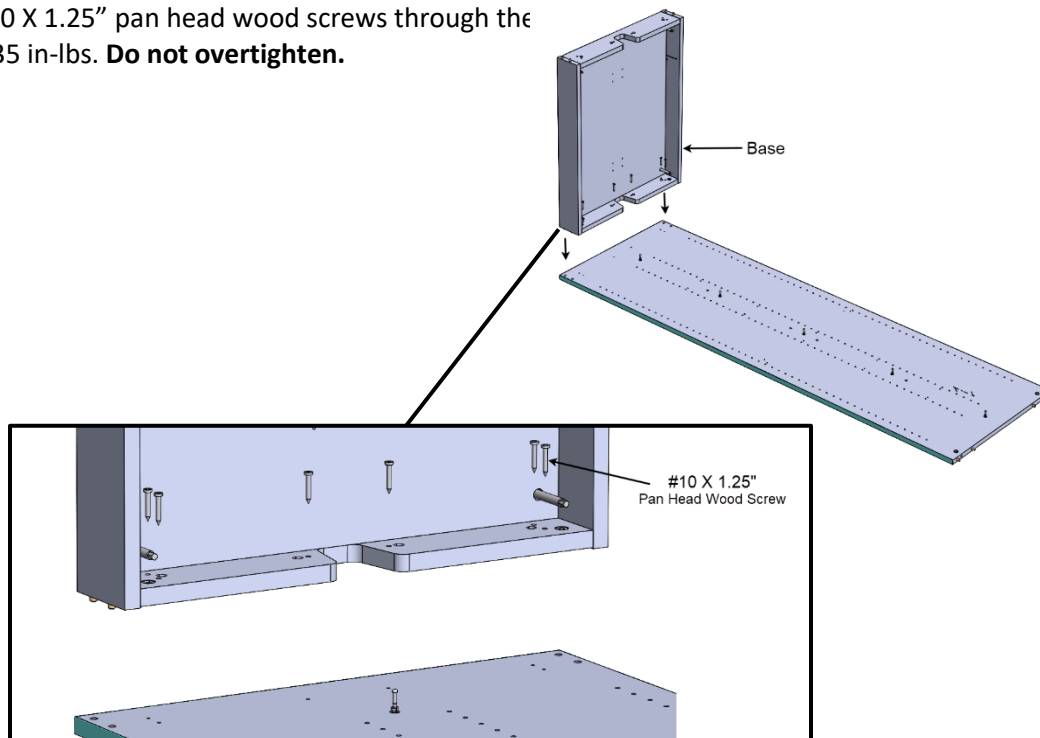

3. Locate Back, (2) 2x2 brackets, #10 X .625" pan head wood screws, and Cams. Push cams into large holes along the perimeter of the back, making sure the **straight arrows point directly towards the closest edge of the panel**. Attach (2) 2x2 brackets to back with (4) #10 X .625" pan head screws using the predrilled holes provided at the bottom of the panel. Note: Unfinished edges of parts are very sharp – we recommend wearing protective gloves when handling.

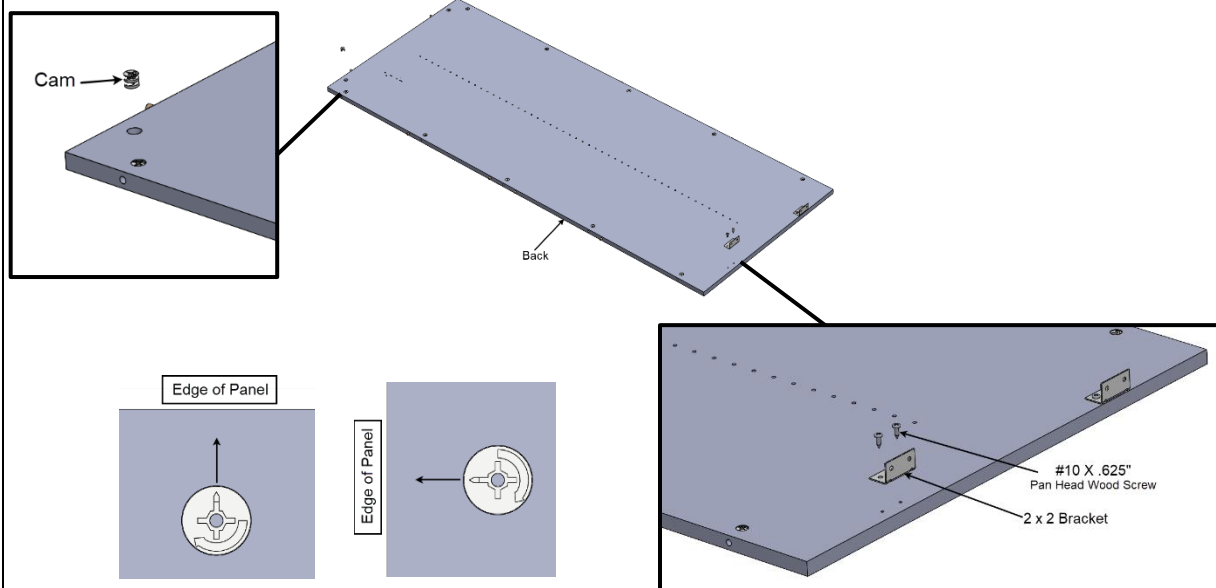

4. Carefully place back onto end while aligning the pins in the end with the cams in back. This may take two people for larger sizes. Using a #3 Phillips Screwdriver, turn the cams along the left side of the Back clockwise until you reach 12-1 o'clock and gaps are closed.

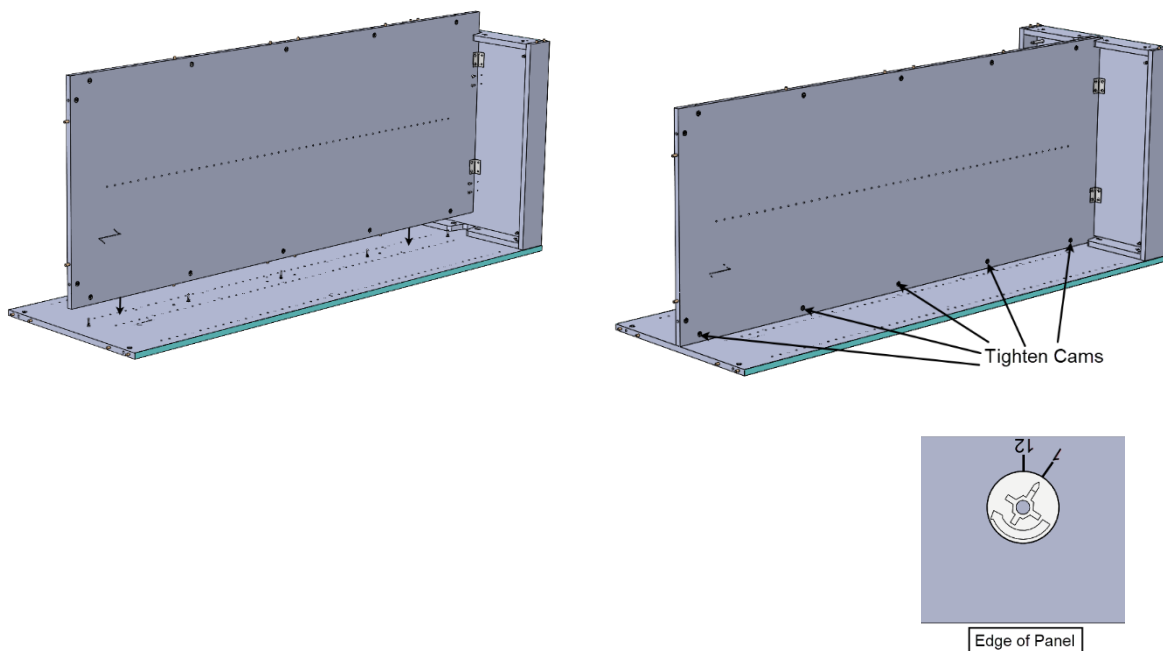



5. Use (4) #10 X .625 pan head wood screws to secure the brackets to the Base Assembly using the provided predrilled holes.

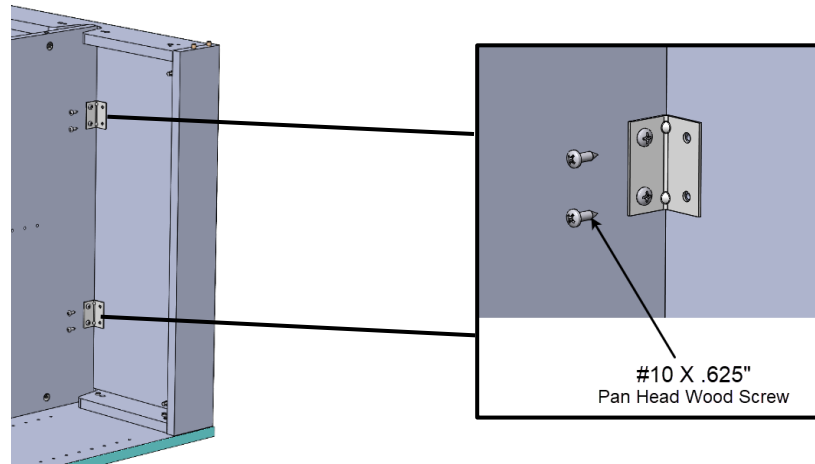

6. Once all screws are installed and back cams are tightened. Carefully flip the product upright and move into position. If only assembling one bookshelf, skip to step 13.

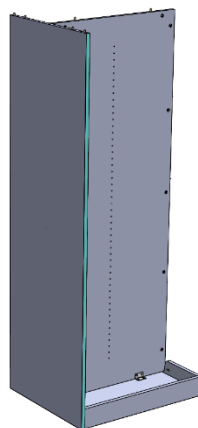

7. Locate double sided pins. Feed a double-sided pin into each of the cams along the side of the back. Turn the cams to 10 o'clock. This is just enough to lock the pins in while allowing them to connect to the cams in the next back.

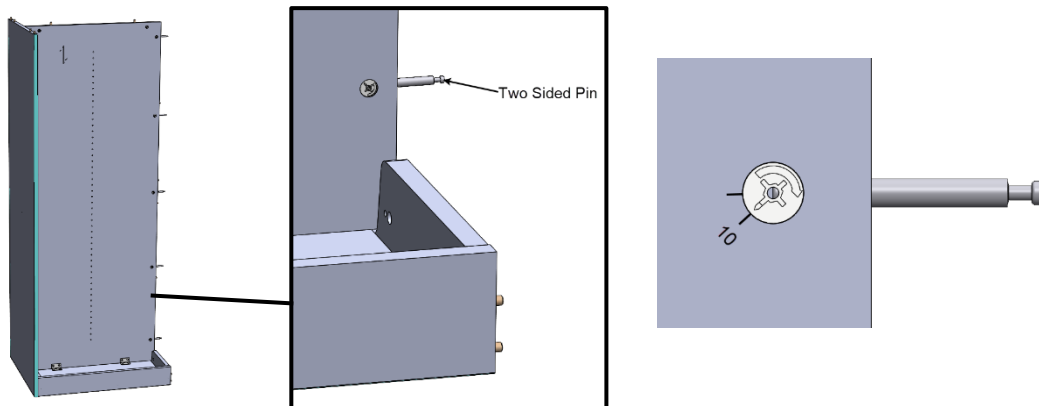

- 8.** Locate an Intermediate Panel and (2) Cams. Intermediate Panels have through holes and notches at the top. Press (2) cams into largest holes at the top of the intermediate panel while pointing straight arrows on cam directly towards the closest edge. Press intermediate panel to starter with cams facing towards the starter, and while aligning the holes with the pins and wood dowels in the back and toe kick.

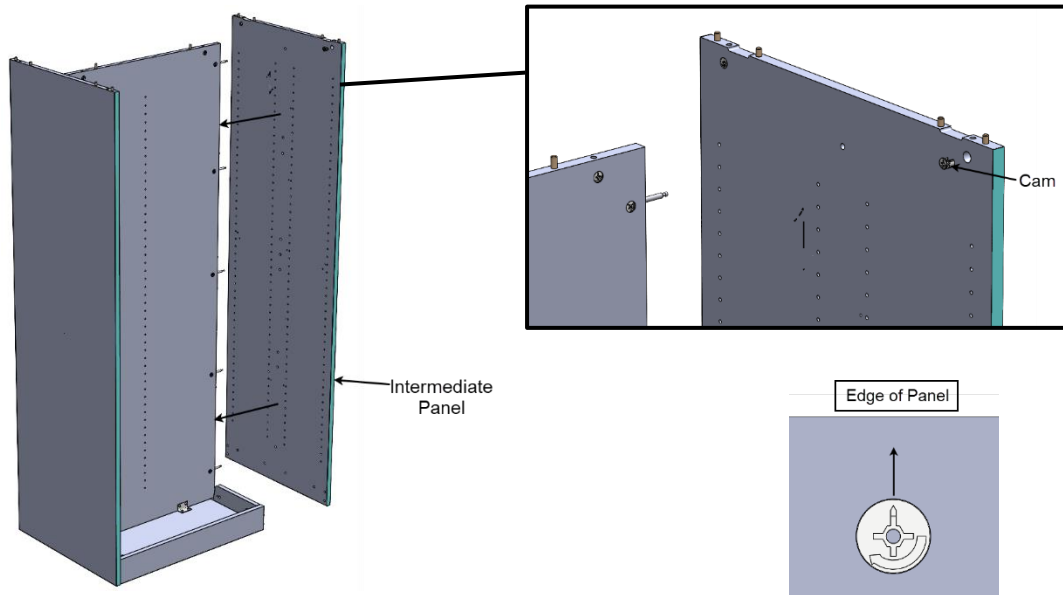

- 9.** Locate next Base, (4) 5/16" X 3" Bolts, (4) Flat Washers, and (4) Flanged Nuts. Press Base to Intermediate Panel while aligning wood dowels in toe kick. It may be necessary to lightly tap the base assembly with a rubber mallet. Feed the (4) 5/16" X 3" bolts with flat washers through the slotted holes in bases and through the holes in the intermediate panels. Thread a flanged nut onto each bolt. Tighten bolts/nuts with (2) 1/2" wrenches until gaps between base assembly rails and the intermediate panel are closed.

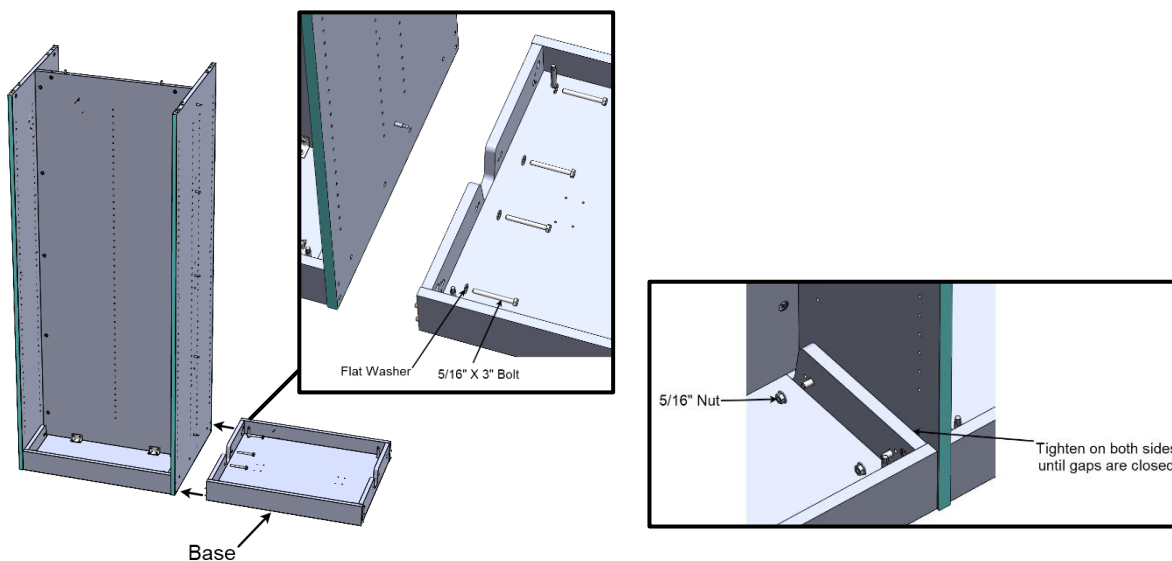

**10.** Locate the next Back, Cams, 2x2 Brackets, and #10 X .625" pan head wood screws. Press cams into each of the large holes with arrow pointed directly towards the edge. Attach the (2) 2x2 brackets to the Back with (4) #10 X .625" pan head screws using the predrilled holes as you did in step 3.

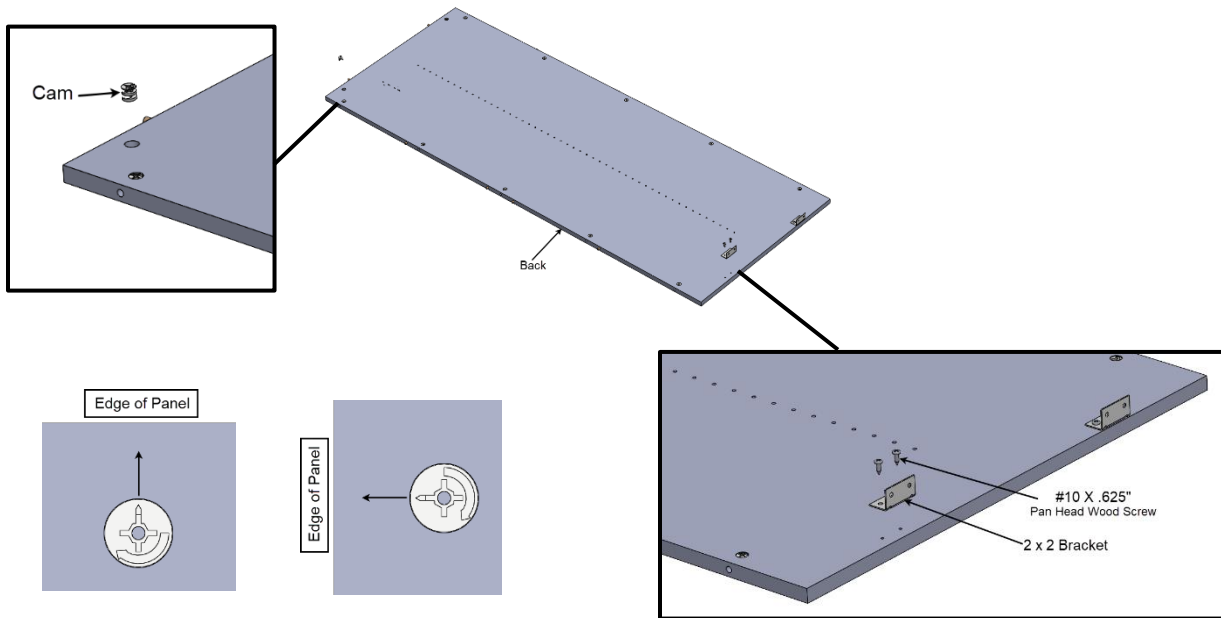

**11.** Place Back into top of base assembly, making sure the cams are facing the same direction as the previous back. Slide the Back to the Intermediate Panel while aligning the wood dowels and pins. You may need to use a rubber mallet to tap the Back and flush it up to the Intermediate Panel. Tighten each of the cams to 12-1 o'clock and gaps are closed. Fasten brackets to Base Assembly with (4) #10 X .625" pan head screws.

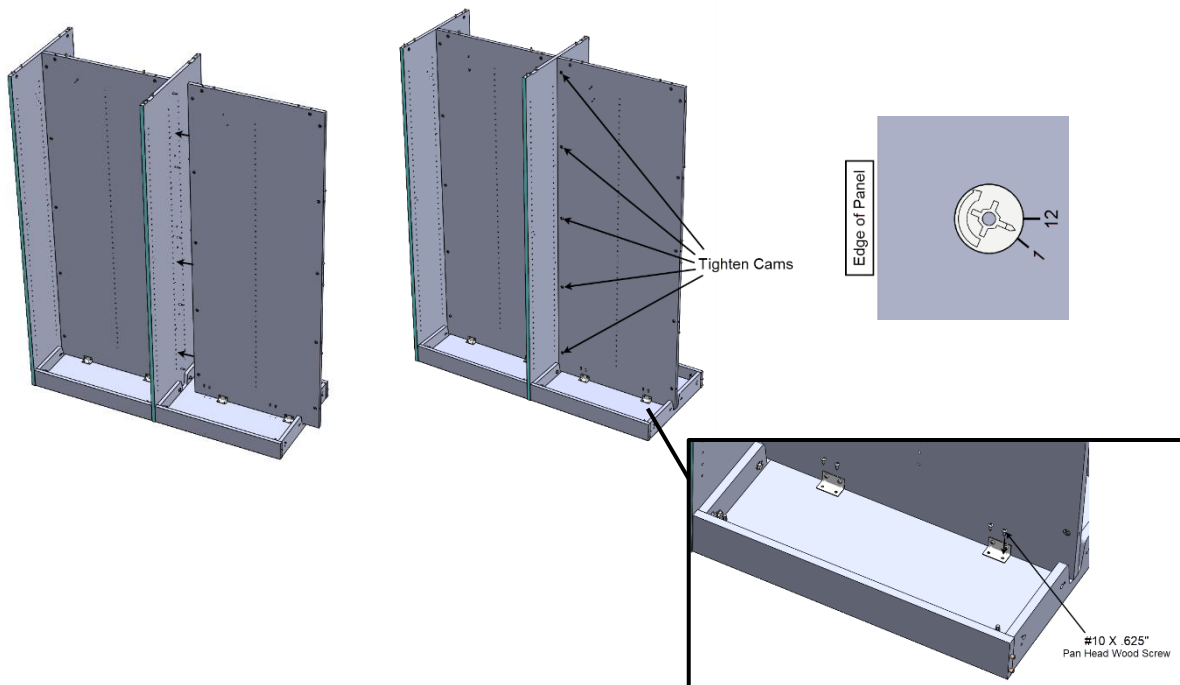

**12.** Repeat steps 7-11 for remaining Adder Bookcases.

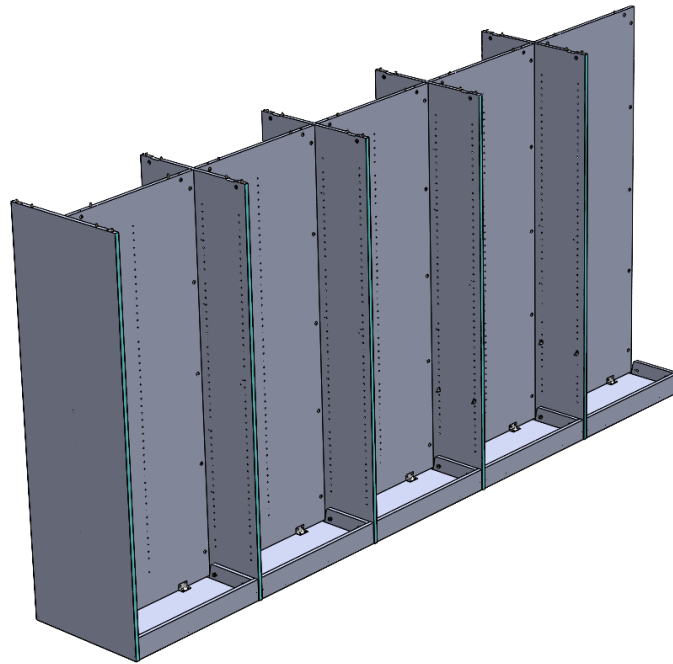

**13.** Locate Finishing End Panel, Cams, and One Sided Pins. Press one sided pins into each of the larger holes along the center of the End. While aligning the pins and wood dowels, tap the End until flush with Back and Base Assembly.

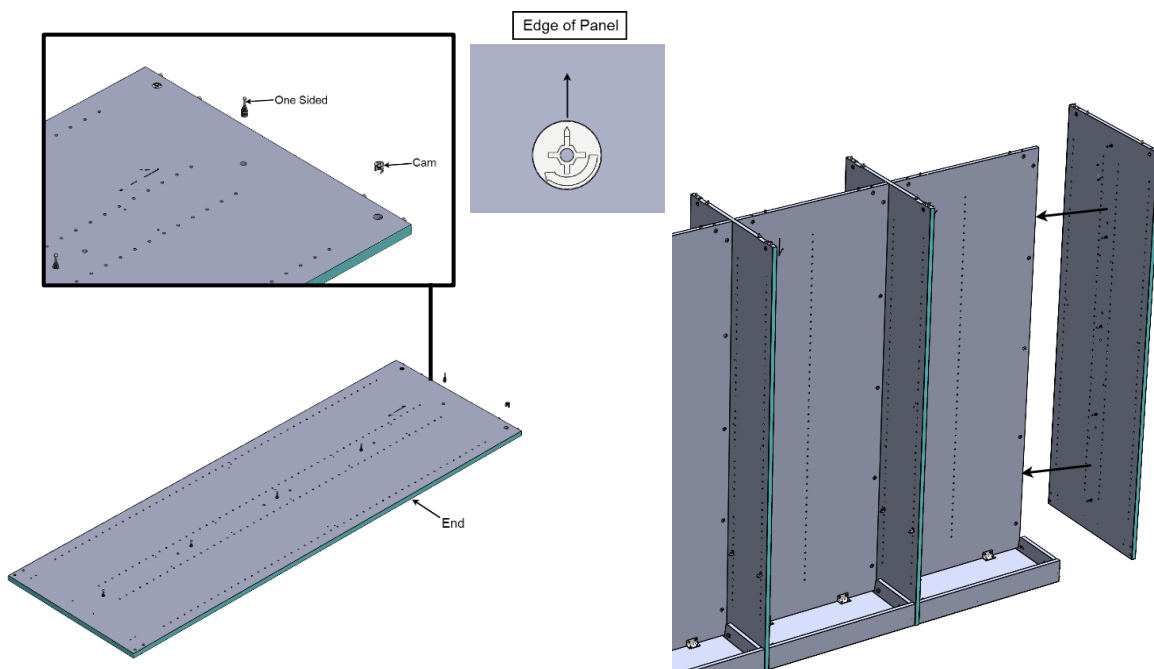

- 14.** Locate (6) #10 X 1.25" pan head wood screws. Drive (6) #10 X 1.25" wood screws through the smaller holes in the Base Assembly into the End Panel on both sides of back. Tighten to a torque of 35 in-lbs. Do not overtighten. Tighten each of the cams in the Back to 12-1 o'clock. If only building one b

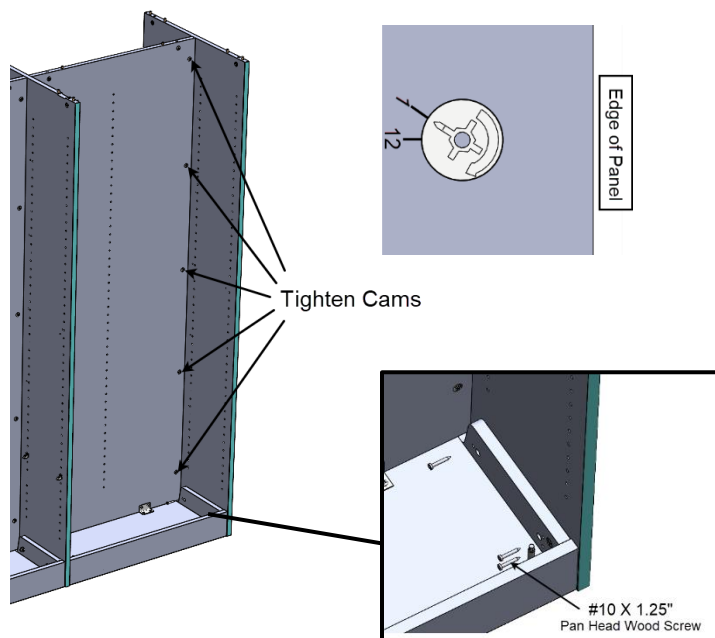

- 15.** Locate the Adder Tops and One Sided Pins. Adder Tops are narrower than the Starter Top and will have mending plates attached to one side. Insert one sided pins into the larger holes along the center and edge of top. Starting with the right-most bookshelf, place an Adder Top onto the bookshelf while aligning the wood dowels and pins. Tap down with a rubber mallet. Tighten the cams in the back and end panel to 12 – 1 o'clock until gaps are closed. Repeat this step for remaining Adder Bookcases.

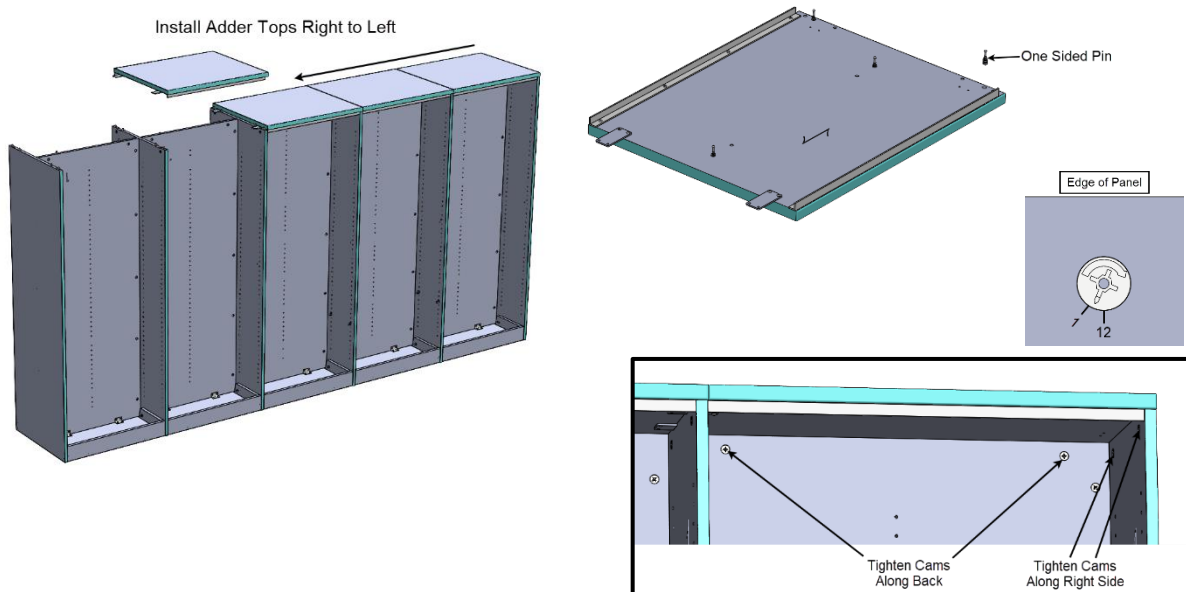

- 16.** Locate Starter Top and One Sided Pins. Insert one sided pins into the larger holes along the center and both sides of the top. The starter top will always be assembled to the left-most bookshelf. Place the top onto the bookcase while aligning the wood dowels and pins. Tap down with rubber mallet. Tighten cams in the Back and the end/intermediate panels to 12-1 o'clock. If only building one bookshelf, skip to step 18.

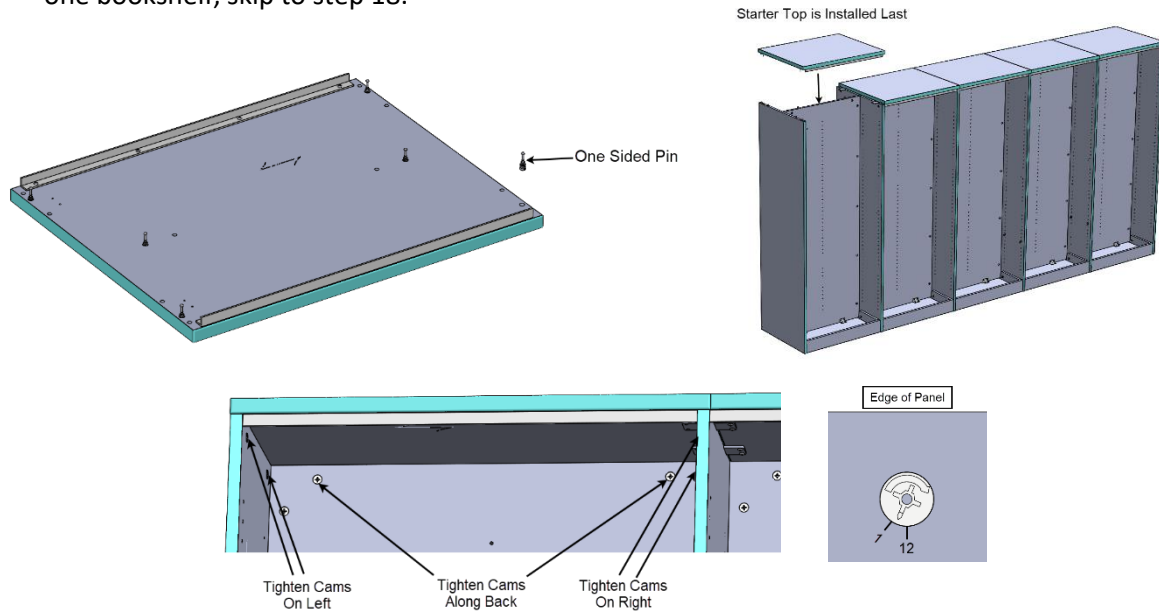

- 17.** Locate #8 X .750" pan head wood screws. Fasten mending plates on each adder top to adjacent top with (4) #8 X .750" pan head wood screws. This ensures that Adder tops are adequately supported.

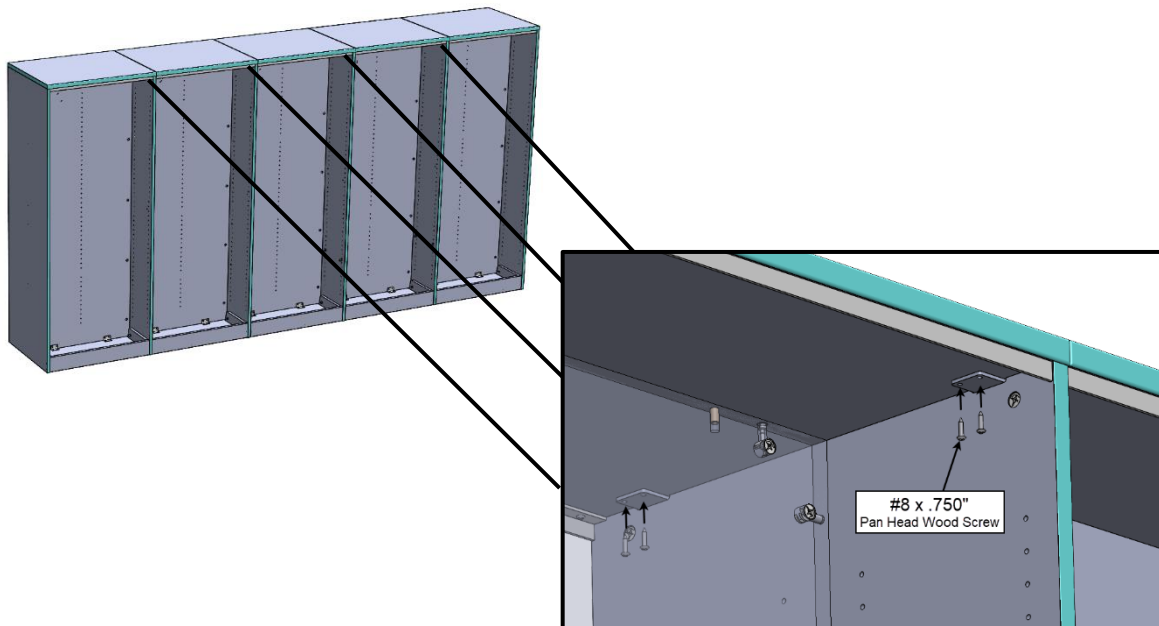

- 18.** Ensure Bookshelves are level by adjusting levelers in base with 1/4" socket. Tip: Bit extensions for drivers are 1/4" sockets. We suggest leveling the first and last bookcases to level the entire run of bookcases first. Then go back and ensure all levelers are touching the ground

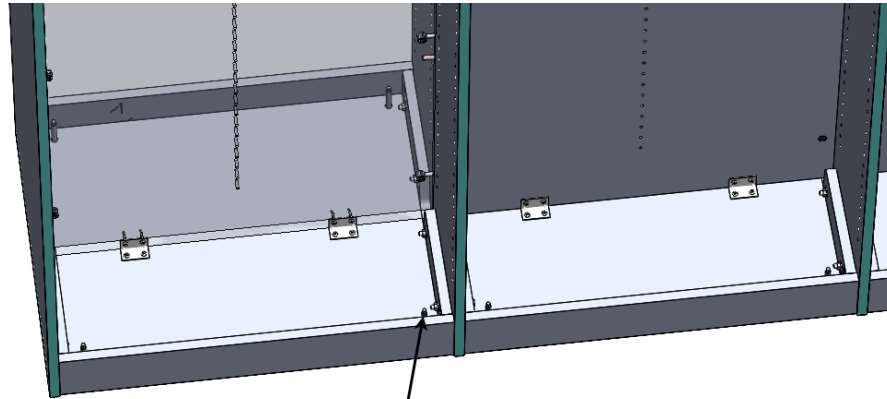

Adjust levelers  
with 1/4" socket

- 19. Bookshelves must be secured to building per local codes before use. We recommend securing to building if over 68" tall, but local codes may differ.** Attaching through the base into the ground is a good option in most situations. Use your own appropriate hardware for the specific application. Once finished, locate the Bottoms and slide 2 of them onto each Base Assembly with bumpers closest to toe kicks.

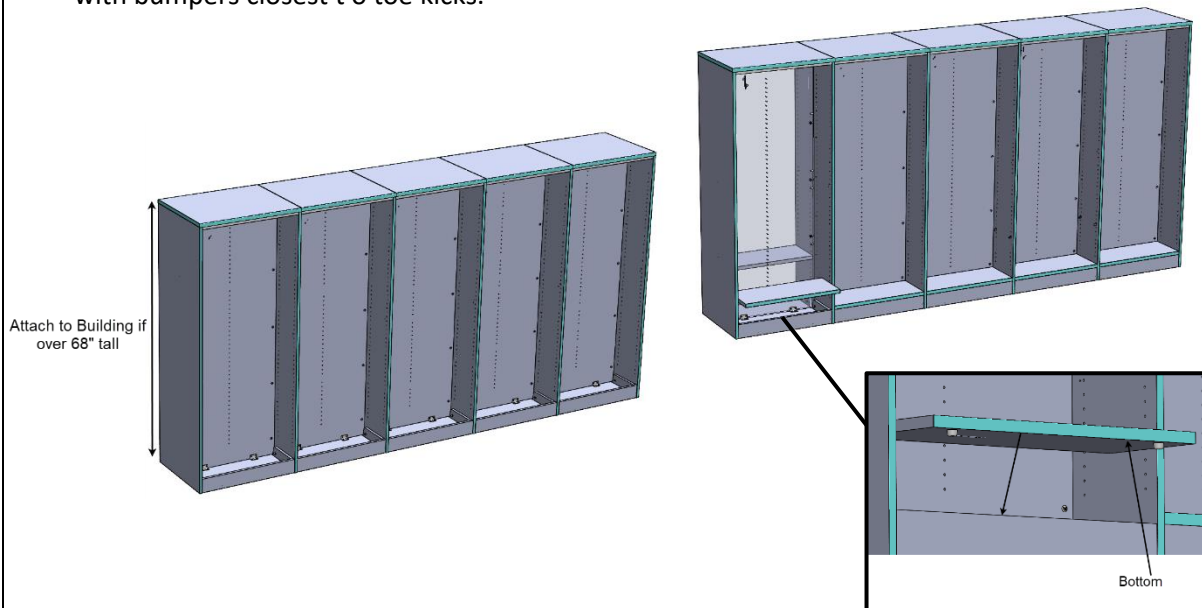

**20.** Locate Shelves and Shelf Hardware. Note there are different shelf types, each with their own hardware.

**Wood Shelves**

Shelf Clips for wood shelves are as shown in the image below. Each wood shelf uses 5 shelf clips – 2 on each side and 1 in the back. Indicator marks behind the rear shelf clip holes in the end/intermediate panels give suggested shelf locations. Place pins the indicated shelf clips holes while making sure the pins in the ends and back are aligned with each other. Ensure that clips are pressed all the way into the holes by giving them a slight twist while inserting. Install shelf on shelf clips while fully seating pins into holes on underside of shelf.

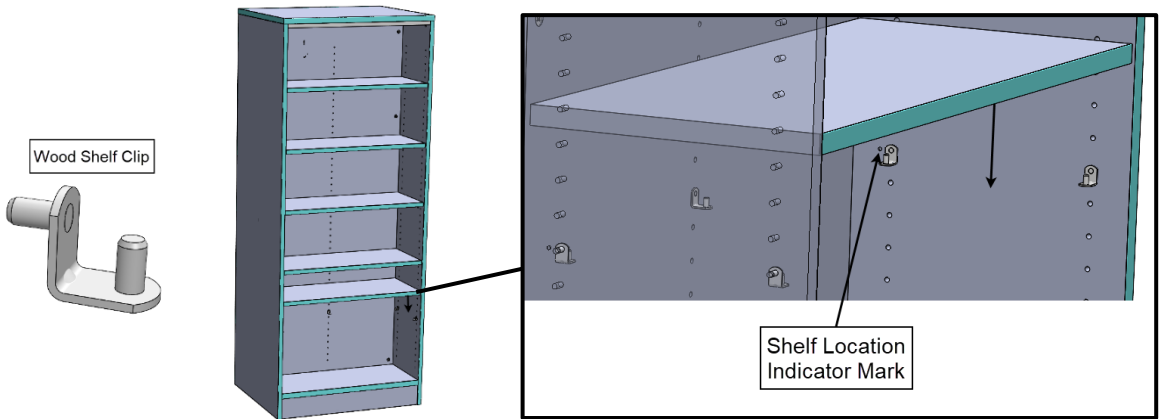

To prevent end panel flexing, cabinets 68" and taller require a fixed shelf on each side of back for Freestanding and on 1<sup>st</sup> and last cabinet in a run. Angle brackets and #10 X .625" Pan Head Wood Screws are provided to fix 3<sup>rd</sup> shelf up. This shelf can be moved to different location, but predrilled holes are provided in suggested shelf location. Attach (2) angle brackets per fixed shelf with (2) #10 X .625" pan head wood screws in small, predrilled holes near the front of the shelf. Use (2) additional screws per shelf to attach bracket to end/intermediate panels.

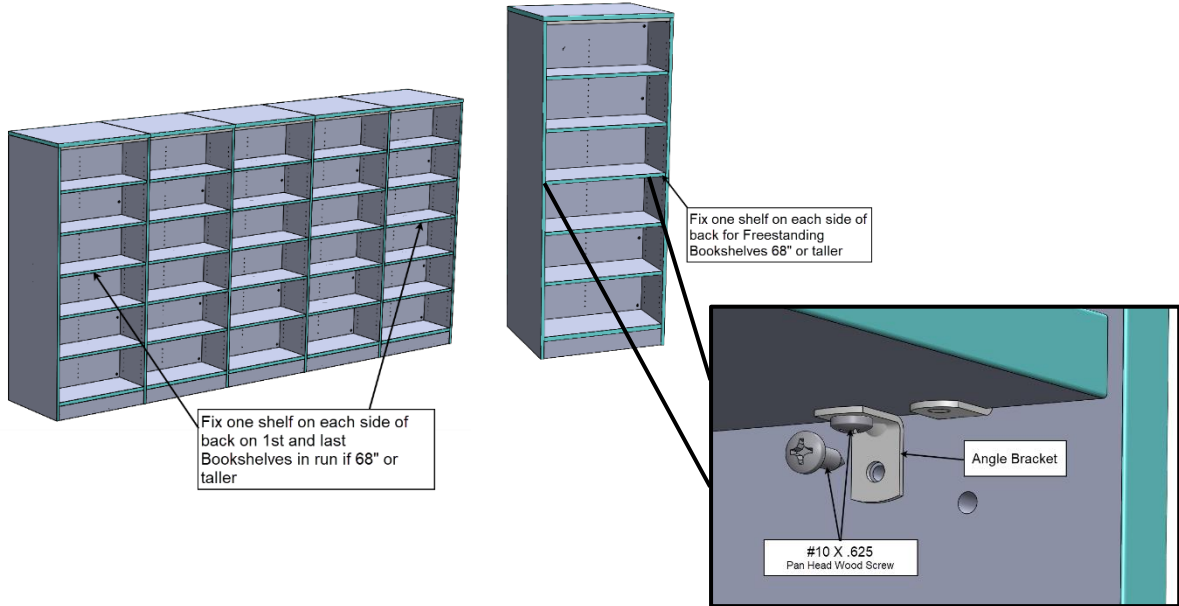



## Metal Shelves

Shelf Clips for metal shelves are as shown in the image below. Each metal shelf uses 4 shelf clips. Small indicator marks behind the shelf clip holes in the end/intermediate panels give suggested shelf locations. Place shelf clips in the indicated shelf clips holes while making sure the clips in the ends are aligned with each other.

Metal Shelf Clip

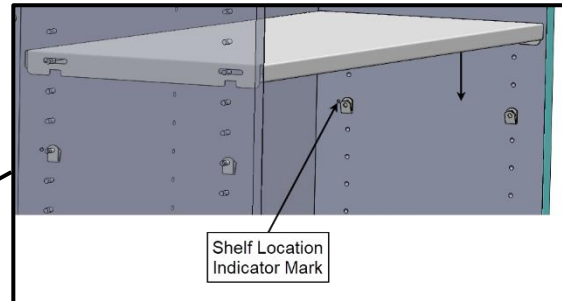
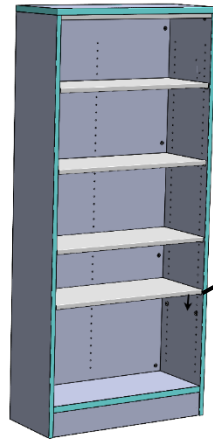

Cabinets 68H and taller require one fixed shelf on 1<sup>st</sup> and last cabinet in a run to prevent end panel flexing. #10 X .625" Pan Head Wood Screws are provided to fix 3<sup>rd</sup> shelf up. Predrilled holes are provided in the end/intermediate panels to drive #10 X .625" pan head wood screws through slots near front of metal shelf.

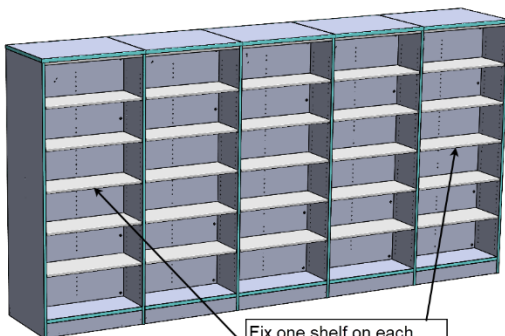

Fix one shelf on each side of back on 1st and last Bookshelves in run if 68" or taller

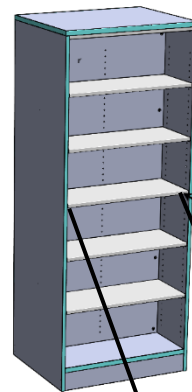

Fix one shelf on each side of back for Freestanding Bookshelves 68" or taller

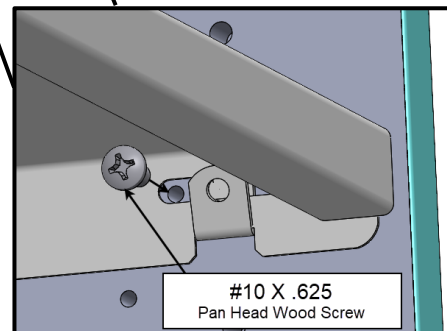

#10 X .625  
Pan Head Wood Screw

## Display Shelves

Straight shelf pins for display shelves are as shown in the image below. Each shelf uses 4 shelf pins. Front Shelf Pins must be spaced 8 holes down from rear shelf pins for pins to align with the slots in the shelves. To install shelf, align the keyhole slots in the rear of the shelf with the rear pins. Then, slide the shelf forward and rotate down as you align the front slots with the front pins.

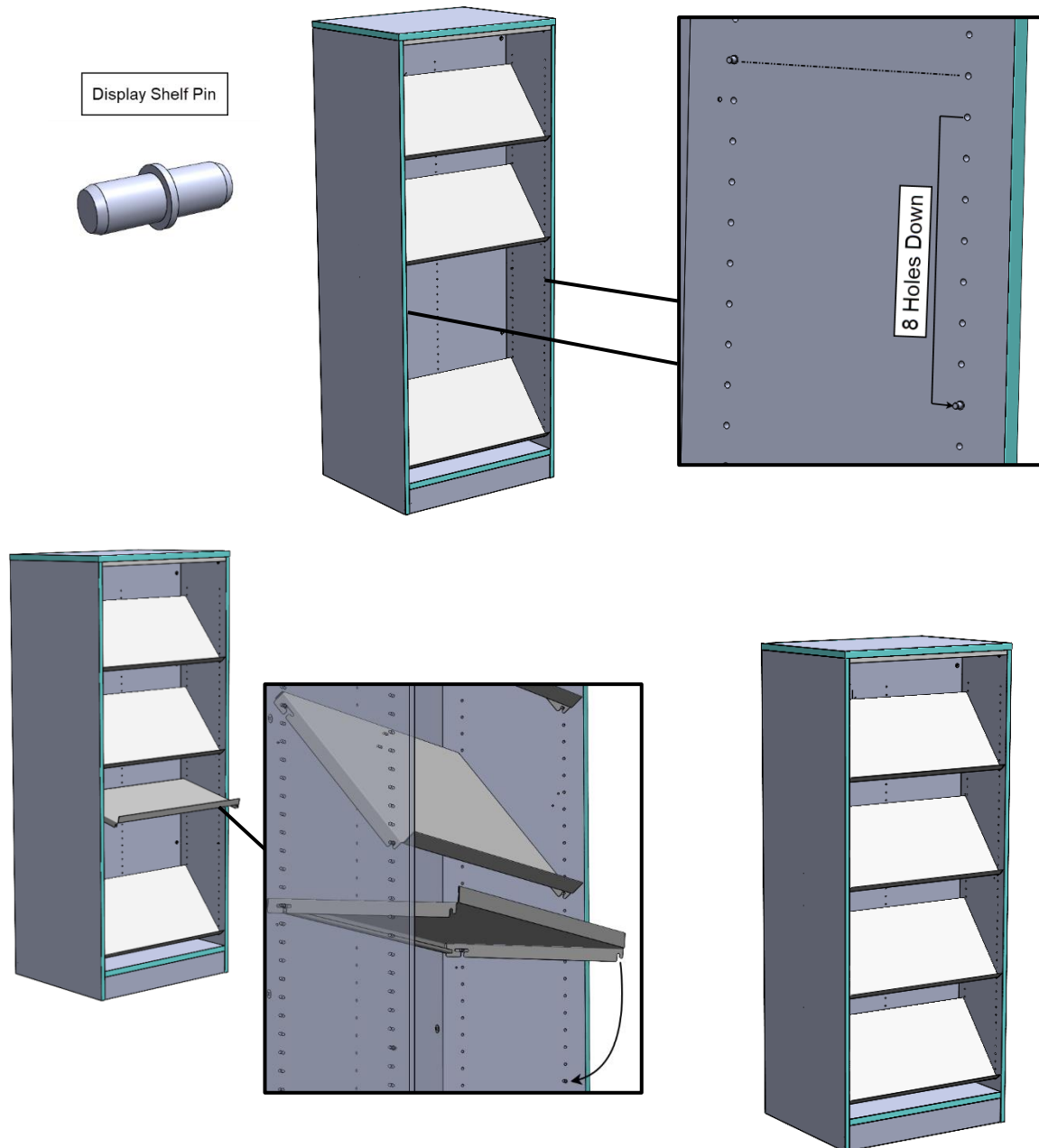

For questions please call us at (616) 396-1142

## Library 2.0 Fillers

12.5" Front Filler and Top Cap

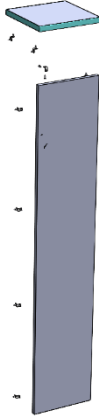

24" Front Filler and Top Cap

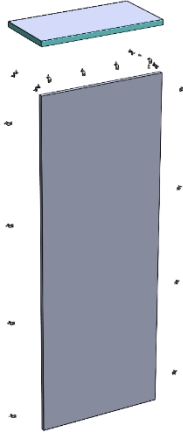

### Tools Required

- Powered Driver
- #2 Driver Bit
- Protective Gloves

### Hardware Included

- Angle Brackets
- #10 X .625" Pan Head Wood Screws

## Inside Corner Application

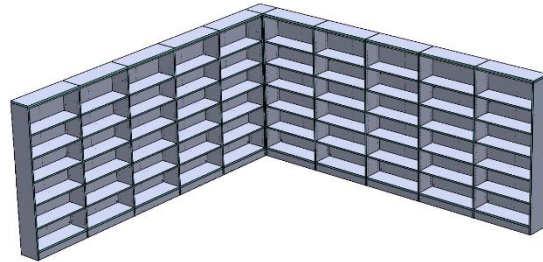

Uses 12.5" Front Filler and Top Cap

## End of Run Application

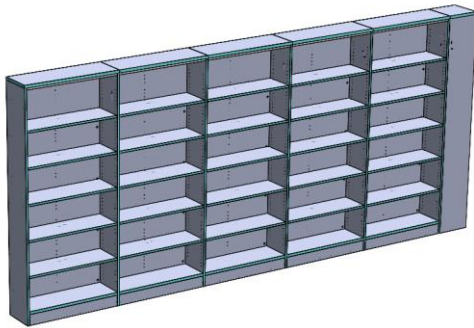

Uses 12.5" Front Filler and Top Cap

## Inline T Configuration

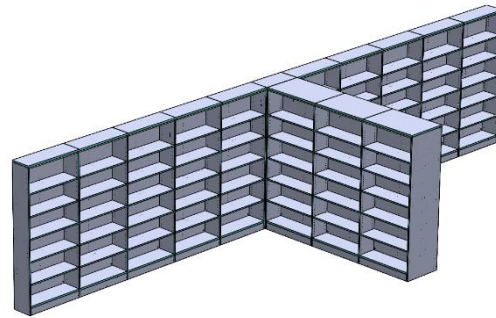

Uses 24" Front Filler and Top Cap

## 12.5" End of Run/Corner Filler

The 12.5" front filler and top cap can be used on either the right or left side of a single sided bookshelf run. They are dimensioned to fit perfectly between two single sided cabinets intersecting at an inside 90 degree corner. They can also be modified to fill any required gap between a single sided bookshelf and a wall. Installation in either application is identical. It requires attaching to the end panel before the end panel is installed to the bookcase. Note that the run of bookshelves may need to be angled outwards and moved into final position once the filler and end panel are installed for wall to wall fit up. Due to the pins and dowels, installation of the end panel requires roughly 1" more space than the final installed dimension.

1. Locate Front Filler Panel and Top Cap. The top cap is slightly shorter than the front filler panel to compensate for the slight overhang of the adjacent bookshelf top. The top cap and front filler will be attached together so that they are flush on the wall mating side. If using in the end of run application, cut part to size to fit gap while keeping the edge band on the top cap on the cabinet mating side, and while keeping the top cap .039" shorter than the front filler. If using for an inside corner application, there is no need to modify parts.

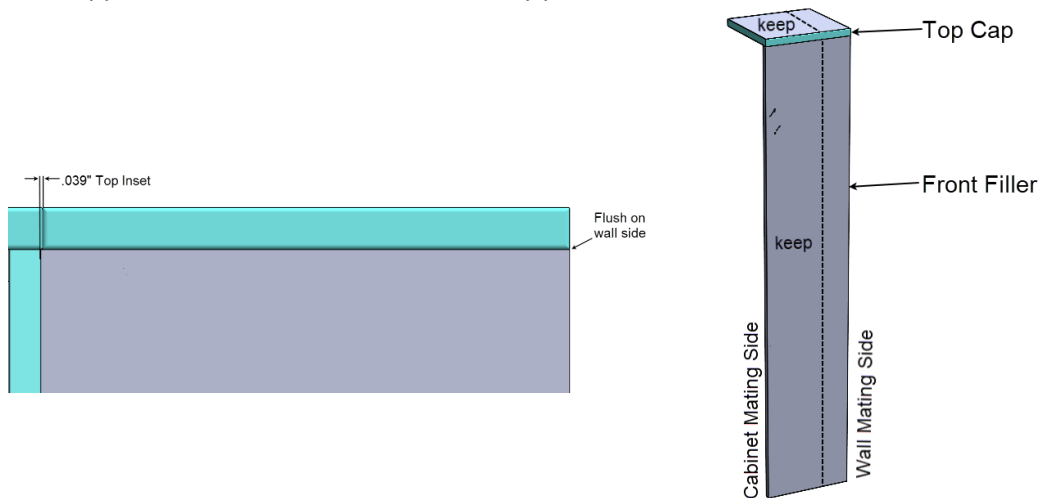

2. Locate Angle Brackets and #10 X .625" Pan Head Wood Screws. Attach (2) angle brackets to top cap using (2) #10 X .625" pan head wood screws on cabinet mating side.

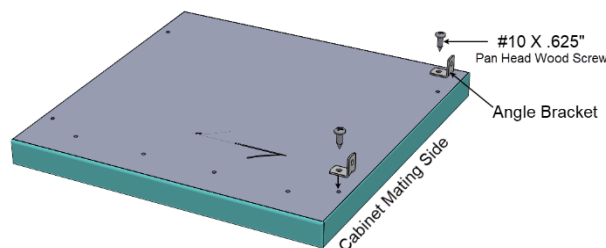

- 3.** Attach angle brackets to front filler panel with #10 X .625" pan head wood screws in all holes along cabinet mating side, and two on top of panel in the left and right most holes. Extra holes are provided for when part is cut down.

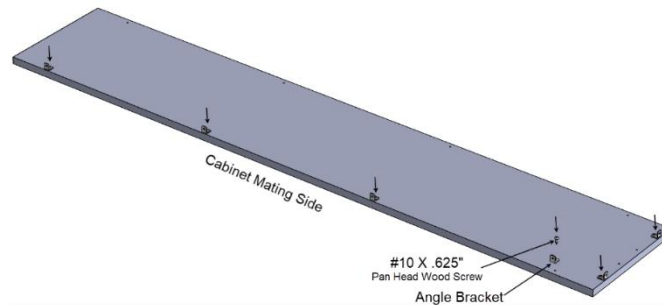

- 4.** Attach top cap to front filler using (2) #10 X .625" screws so that the top cap and front filler are flush on the wall mating side.

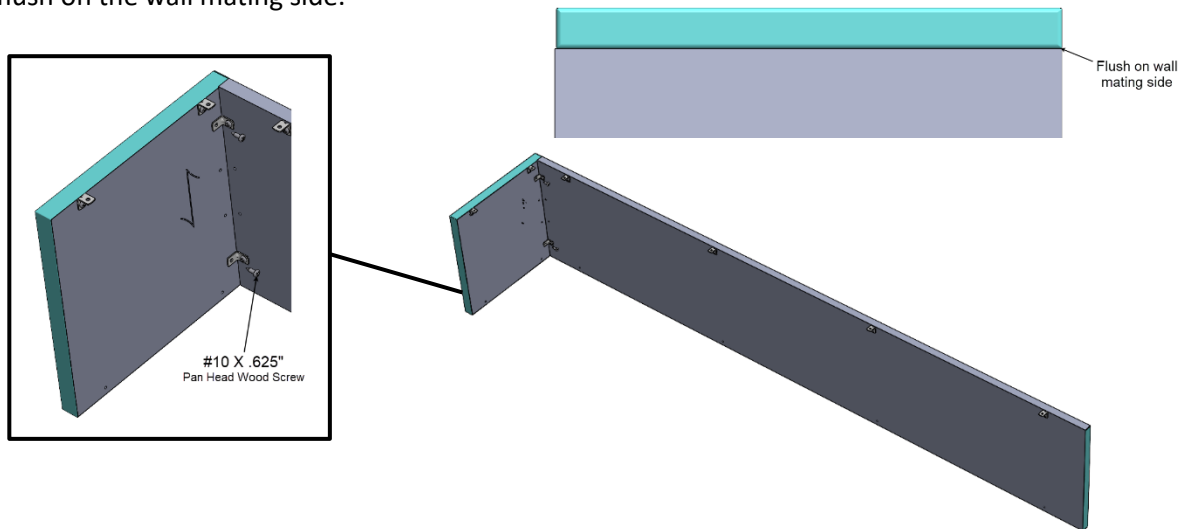

- 5.** Locate LH or RH bookshelf end panel. Lay ground so that holes are facing down. Place filler assembly onto end panel. Position so that front panel is flush with the end panel on top and bottom, and offset by the edge banding thickness from the front.

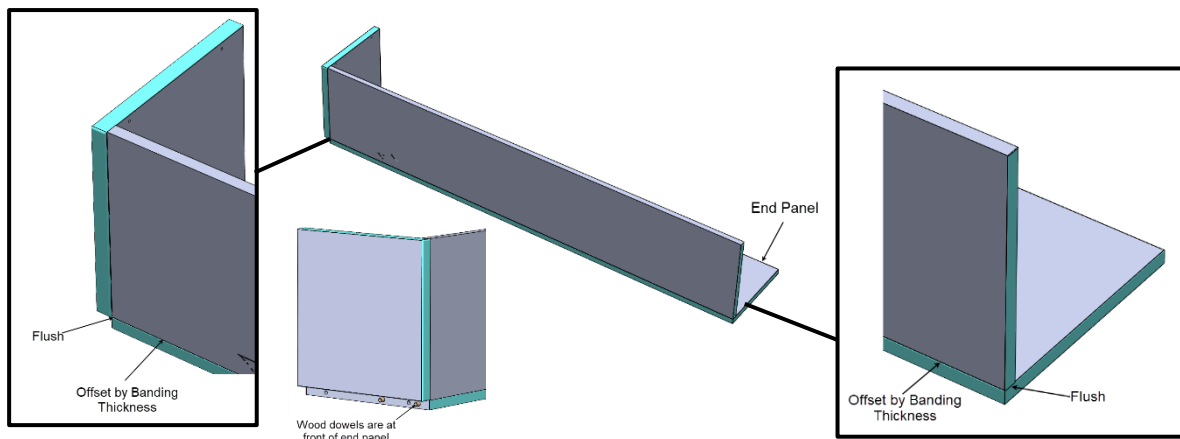

6. Use a  $9/64$ " drill bit to pre-drill into the end panel .5" deep in every open angle bracket hole. Attach Filler Assembly to End Panel with #10 X .625" pan head wood screws at each bracket.

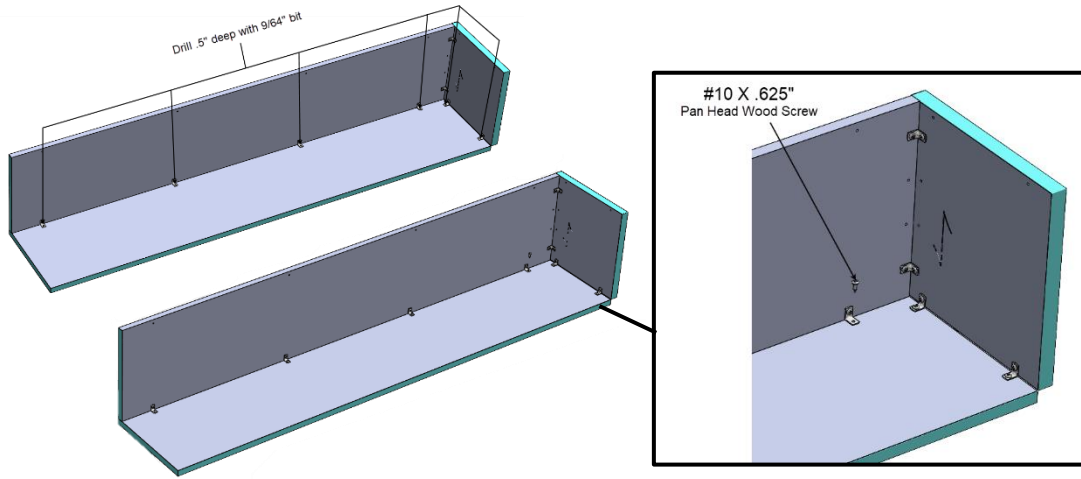

7. Attach End Panel to bookshelf as described in 957890-INST. Note that the run may need to be angled outwards and moved into final position once the filler and end panel are installed for wall to wall fit up. Due to the pins and dowels, installation of the end panel requires roughly 1" more space than the final installed dimension.

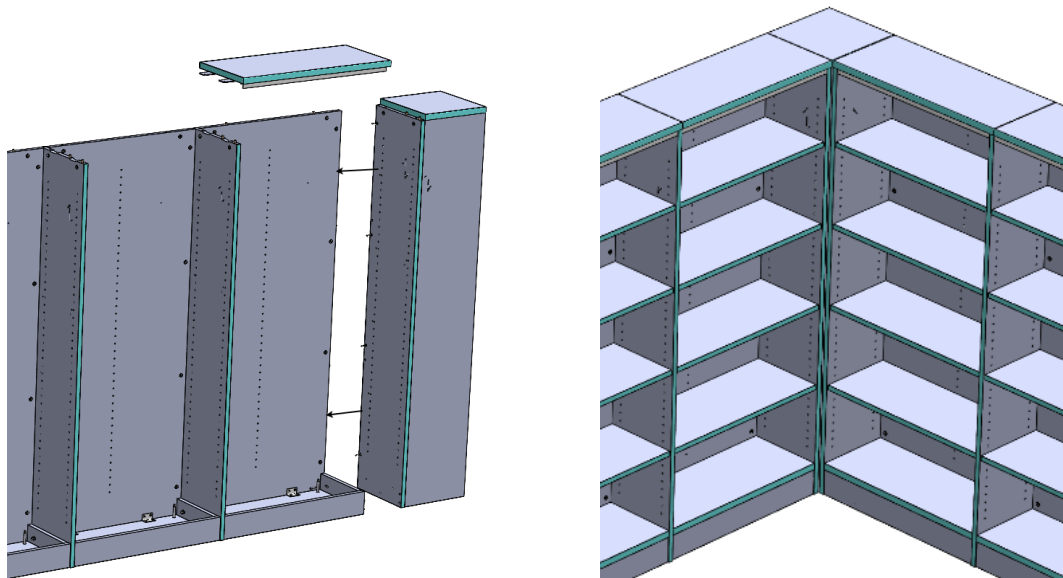

## 24" Inline T Filler

The 24" front filler and top cap are used in between two single sided bookshelves. They are dimensioned to match the depth of a double sided bookshelf to support a T configuration layout. They can also be cut and modified for other applications if needed. Installation in the Inline/T application requires attaching to both a LH and RH end panel before they are installed to the bookshelves.

1. Locate Front Filler Panel and Top Cap. The top cap is slightly shorter than the front filler panel to compensate for the slight overhang of the adjacent bookshelf tops. The top cap and front filler will be attached together so that the top cap is inset equally on each side.

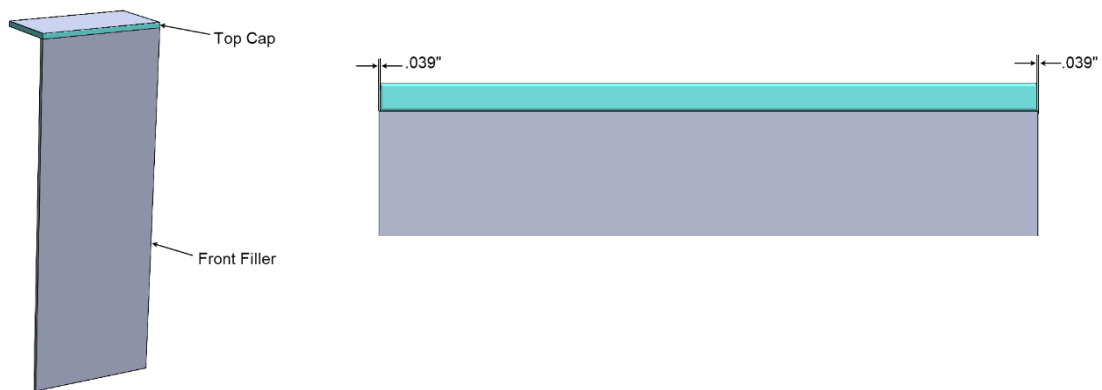

2. Locate Angle Brackets and #10 X .625" Pan Head Wood Screws. Attach angle brackets at the predrilled holes on each side of top cap using (4) #10 X .625" pan head wood screws.

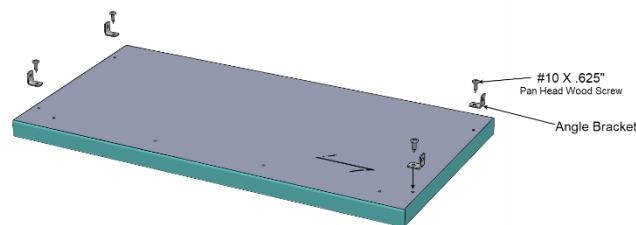

3. Attach angle brackets to front filler panel with #10 X .625" pan head wood screws in all holes along the sides and top of panel.

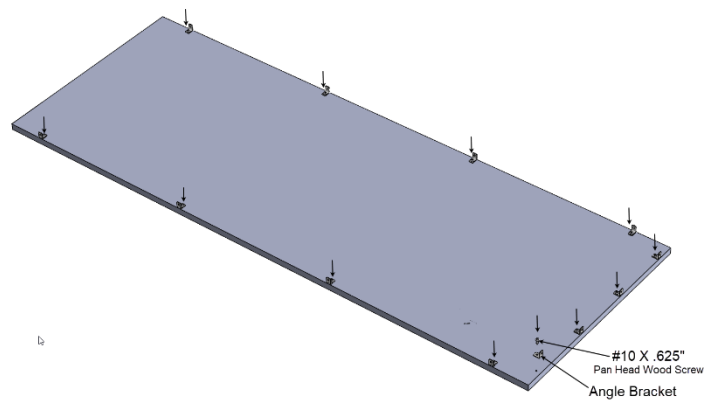

4. Attach top cap to front filler using (4) #10 X .625" screws so that the top is inset equally on each side.

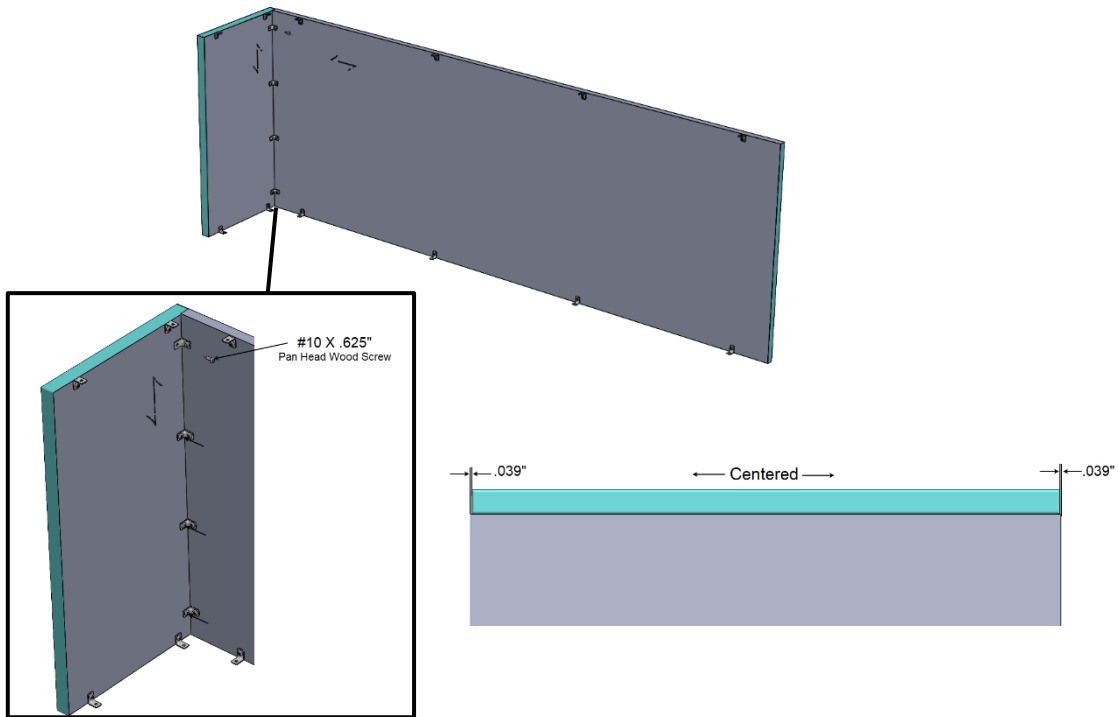

5. Locate LH and RH single sided end panels. Lay one end panel on ground so that holes are facing down. Place filler assembly onto end panel. Position so that front panel is flush with the end panel top and bottom, and offset by the edge band thickness from the front.

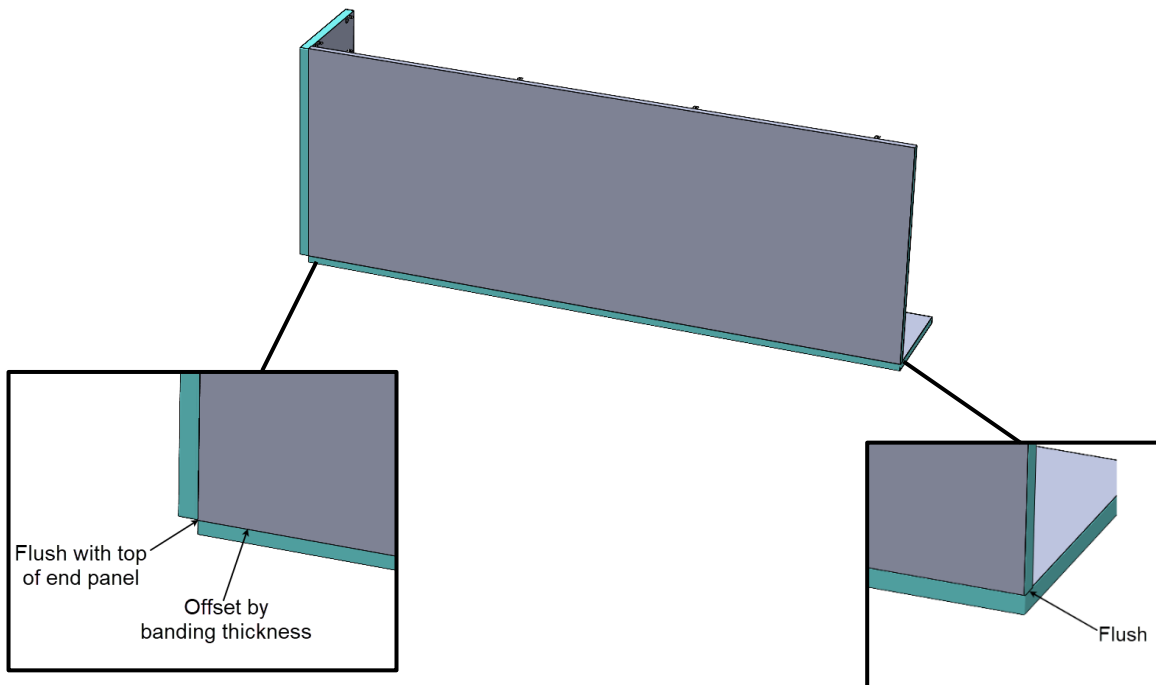



6. Use a 9/64" drill bit to pre-drill into the end panel .5" deep in every open angle bracket hole. Attach Filler Assembly to End Panel with #10 X .625" pan head wood screws at each bracket. Repeat steps 5 and 6 for the other end panel.

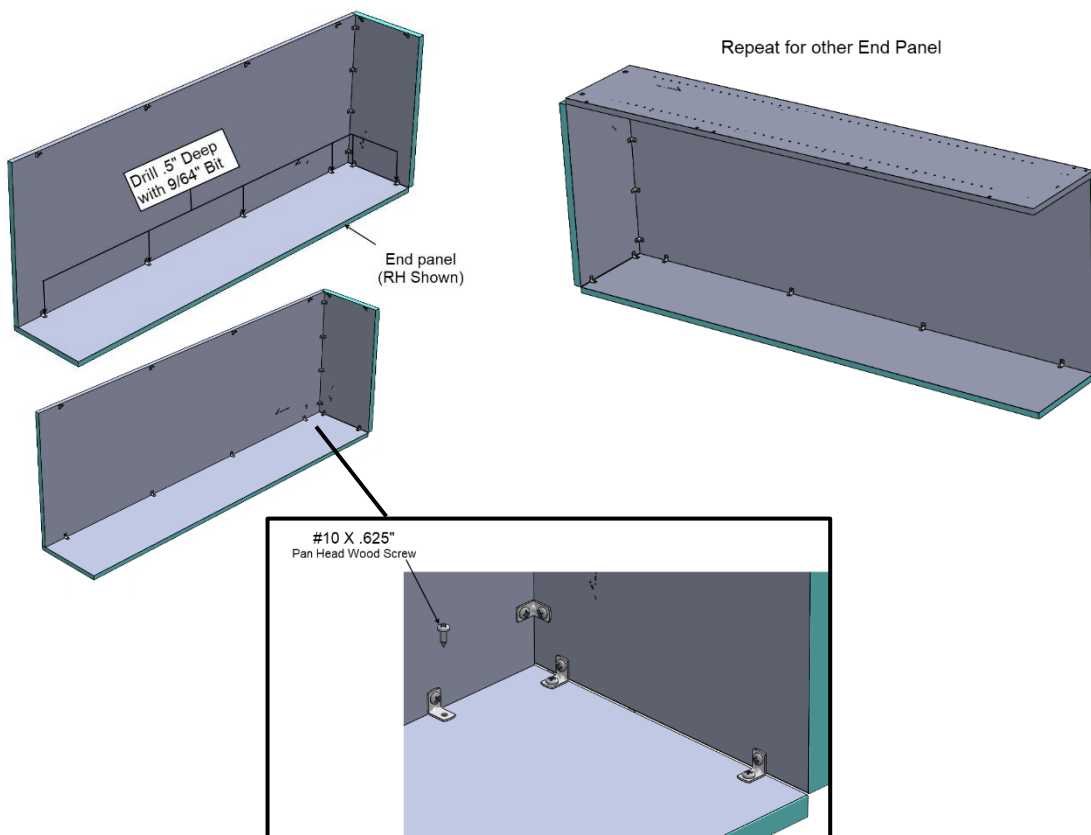

7. Attach End Panels bookshelves as described in 957890-INST. Note that it will be easiest to install this assembly onto to the end of the first run of bookshelves and before starting the 2<sup>nd</sup> run of bookshelves.

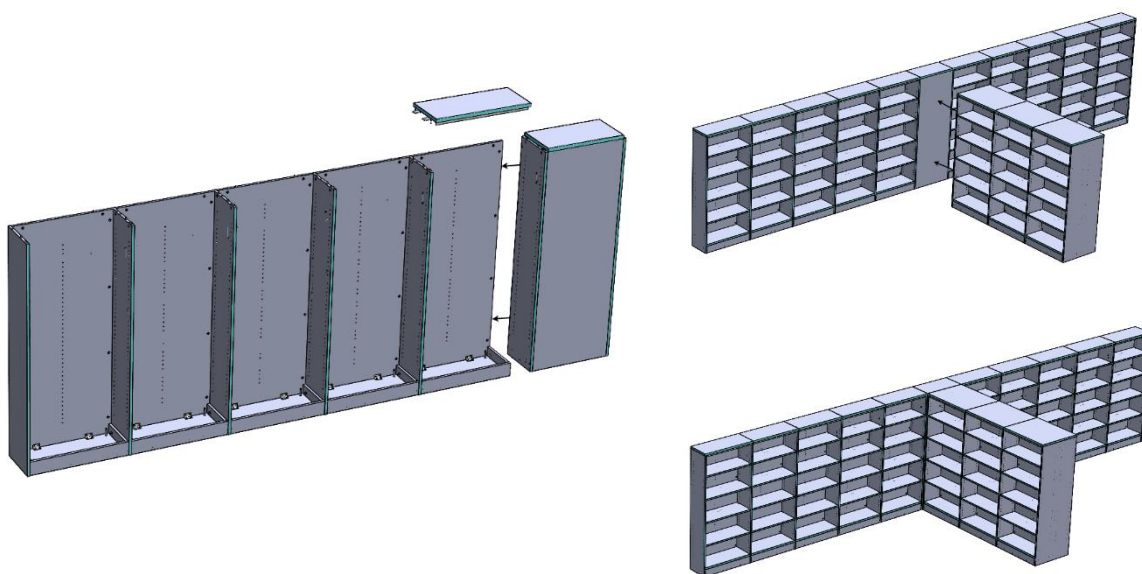

# Library 2.0 Bookshelf Filler Instructions

960950-INST  
Rev. A

For questions please call us at (616) 396-1142